

ELEMENT

CLUB SERIES

4



INSTALLATION MANUAL

CLUB 140



PLEASE LEAVE THESE INSTRUCTIONS BEHIND WITH THE DEVICE

TABLE OF CONTENTS

1 CE STATEMENT	4
2 IMPORTANT SAFETY INFORMATION	4
3 WARRANTY	5
4 REMOTE CONTROL WITH FULL ELECTRONIC IGNITION	6
4.1 Adjusting the communication code	6
4.2 Igniting the pilot light	6
4.3 Igniting the main burner	6
4.4 Switching off the fireplace	6
5 INSTALLATION PREPARATION AND - INSTRUCTION	7
5.1 Relevant norms and guidelines	7
5.2 Attention points gas fireplace	7
5.3 Attention points gas connection	7
5.4 Requirements flue and wall terminals	7
5.5 The chimney	7
6 FIRE SAFE INSTALLATION	8
6.1 Fire safety device set-up	8
6.2 Assembly regulations	8
6.3 Assembly regulations with flammable materials	9
7 ATTENTION POINTS GAS FLUE	10
7.1 Installation of flue material	10
8 INSTALLATION CHECK AND FIRST USAGE	10
8.1 Renovation/new construction	10
8.2 Checking the gas lines	10
9 ELECTRICAL CIRCUIT	11
9.1 Element4 ProControl App.	11
9.2 Domotica	11
10 MAINTENANCE INSTRUCTION	12
10.1 Maintenance in the combustion chamber	12
10.2 Cleaning the glass	14
11 PLACING THE DECORATION MATERIAL	16
12 LED-LIGHTING	16
12.1 Function of the handheld transmitter for the Club Series	16
12.2 LED ports	16
13 USER INSTRUCTION	17
13.1 Hand over to the customer	17
13.2 Maintenance instructions for the installer	17
13.3 Anti-reflective glass	17
13.4 Replacement of parts	17
13.5 Packaging materials	17
A FIRST AID FOR MALFUNCTION	18
B ERRORS CODES PROCONTROL APP	22
B.1 Messages shown in app	22
B.2 Messages shown in remote	23
C FAULTS AND ERROR CODES IN THE REMOTE	24
C.1 F41 error	24
C.2 Router information	24
D LOCATION TERMINAL	25
D.1 Terminal location with vertical exhaust (C11)	25
D.2 Terminal location with Horizontal exhaust (C31)	25
E GENERAL RULES FOR FLUE GAS EXTRACTION	26
E.1 Power-Fan	26
E.2 Determining the flue gas extraction diameter	26
F CALCULATION TABLE FLUE GAS REDUCTION	27
F.1 Horizontal terminal flue diameter 200/130	27
F.2 Vertical terminal flue diameter 200/130	27
G TECHNICAL DATA	28
H ECODESIGN	29
H.1 Ecolabels	29
I DIMENSIONAL DRAWINGS	30

1 CE STATEMENT

We hereby declare that the design and construction of the Element4 gas appliances are complying to the essential demands and regulations for gas products.

Product:

- Gas fireplace, local spaceheater

Model:

E4-10

- Club 140 F
- Club 140 CL
- Club 140 CR
- Club 140 3S

E4-11

- Club 140 RD
- Club 140 T

Applicable EG-guidelines: (EU) 2016/426 (GAR)

Applicable harmonized norms:

- NEN-EN-613
- NEN-EN-613/A1

This declaration loses its validity when changes to the device are made without the written permission by Element4. You can ask for a copy of the test certificates of all models via our general e-mail adress, which is found on the back of this manual.



J. Kempers
CEO

2 IMPORTANT SAFETY INFORMATION

The fireplace may only be installed by a qualified installer/dealer, following these installation instructions. We advise you to read these instructions properly, before commencing the installation of your device.

Before installation check the device for transport damage and inform your supplier immediately if damage is found.

Check the data on the dataplaat. The gas type and pressure should check out with those locally available. The data plate is mounted to the device. Make sure it is accessible at all times.

This device is design to be used with natural gas or LPG. The device can only be used with the type of gas specified on the data plate at the time of purchase.

Do not use this device as a primary heat source!

The device may never be used without the glass of when glass is broken. The flue gasses can get into the installation room. The settings and construction of the device must not be changed!

Parts are only to be changed with original parts by the original manufacturer.

The device is provided with a special set of decorative materials. Do not place any extra imitation logs or decoration material on the burner or in the combustion chamber. See chapter 11 for an instruction on how to arrange the decoration properly.

The glass and frame on this appliance acts as a fireguard conforming to BS: 1945 – 1971 and satisfies the Heating Appliance (Fireguards) regulations 1991. No part of the window or frame should be permanently removed. It does not give protection for young children aged or infirm, extra guarding (conforming to BS8423: 2002) should be considered so the special hazards that exist in nurseries and other places where there are young children, aged or infirm persons are minimized.

The heat that is coming from the device may effect the materials in its surroundings. Always take into account to correct safety distances. For more information see chapter 6.

3 WARRANTY

NB: Should a problem occur, that you are not able to fix yourself with the help of the support in Appendices A to C, please contact your installer or dealer.

The Element4 devices on which this warranty is applicable are made of high quality materials. Should any problem or defects still occur the following provision are in effect;

1. Before any installation, the installer will ensure himself of the good quality and operation of the flue channel. The gas fireplaces are to be installed by a competent installer, according to the rules and regulations that are applicable in the country (or even region) of installation and those as described in this manual.
2. There is a warranty period of two years for all Element4 devices, starting from the moment of purchase. The date of purchase should be mentioned clearly on the purchase invoice.
3. The ceramic glass is not included in the warranty, as are the physical or chemical outside influences during transport, storage or montage.
4. If a malfunction should occur during warranty period that is a consequence of an assembly error or material defect, Element4 will provide a free replacement part to the installer, without compensation for disassembly or montage.
5. In case the installer is not able to fix the problem himself, a request can be made to Element4 to do it for him, as long as the service can be done within the borders of the Benelux.
6. Only after consultation up front, the device or loose parts can be sent for check up or replacement. These goods are to be sent with the necessary warranty documents and the date of purchase.
7. When a house visit should occur for service purposes by Element4 (within the borders of the Benelux) during warranty period, the right documentation (i.e. this page and a proof of purchase) should be available.

For a service provision to house, outside the warranty period, the following costs are being charged:

- Material costs
- Working hours
- Call-out costs

The warranty is not applicable in the following cases:

1. When one of the previous points is not met
2. When changes are made, of which Element4 is not made aware of / has approved of upfront
3. When device is not installed and/or used properly according to the installation manual.
4. When other than the prescribed decoration material is used.
5. When the device is installed (partially or fully) with other materials than prescribed in this manual.

4 REMOTE CONTROL WITH FULL ELECTRONIC IGNITION

The unit is operated using a remote control (*Fig. 4.1*) or the Element4 Puck, connected to a receiver (*Fig. 4.2*).

The receiver is powered by 4 pen lite (type AA) batteries or a 6V adapter; 2 penlight batteries (type AAA) are used for the remote control. The life of the batteries is about a year with normal use.

4.1 Adjusting the communication code

Before using the appliance, a communication code must be set between the remote control and the receiver. The code is chosen at random from the 65000 available codes. Therefore there is a slim chance that other remotes in your area use the same code.

Please do the following

Press the reset button on the receiver until you hear two beeps. After the second longer signal, let go of the reset button (*Fig. 4.2*).

Within 20 seconds, press the down arrow on the remote control until you hear a sound signal. This is confirmation of the proper communication.

4.2 Igniting the pilot light

Check that the control knob (A) is in the ON position (*Fig 4.3*). Press the button on/off button of your remote control and continue to hold down (3 to 5 sec.) until you hear two short beeps.

The ignition sign will appear at the top of the screen (*Fig. 4.1*) Now release the button. The ignition procedure is started.

NB: If the pilot light doesn't remain lit after 3 attempts you must turn off the gas tap and warn your installer.

4.3 Igniting the main burner

After starting the pilot, knob B will automatically rotate counter clockwise and the main burner will start burning (*Fig 4.3*). Always wait 5 minutes after killing the pilot light before you start the pilot flame again.

NB: The pilot light must ignite the main burner, evenly and without a thud, if it does thud, close the gas tap and warn your installer.

4.4 Switching off the fireplace

You switch off the fireplace by pressing the on/off button, this also turns off the pilot light! For a detailed description of the E-save remote control, please refer to the E-save manual which is included with the fireplace.

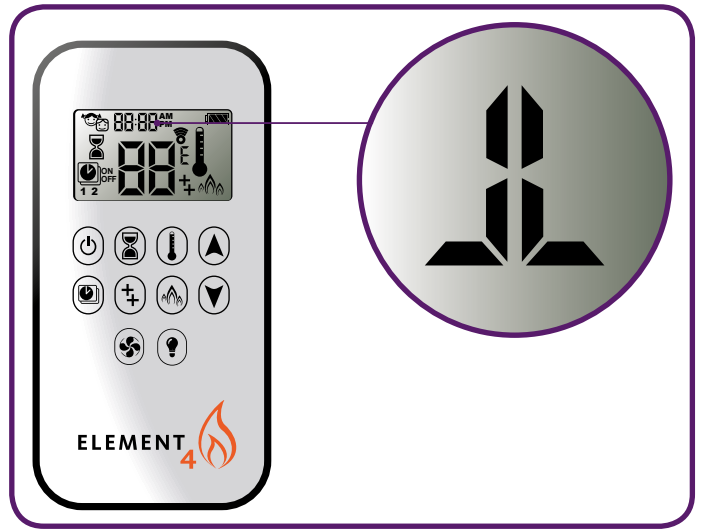

Figure 4.1 - Remote and ignition sign



Figure 4.2 - Receiver

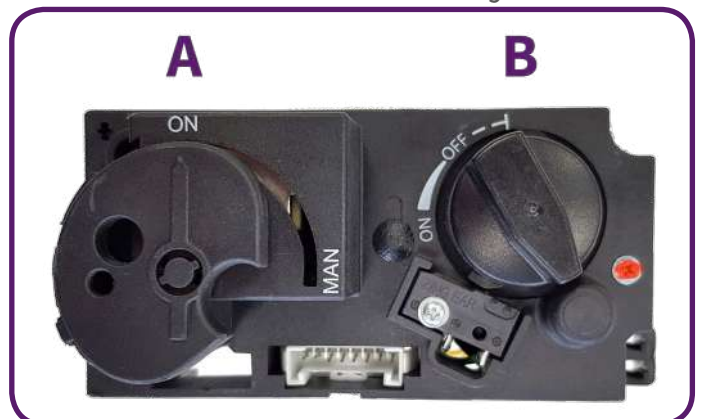

Figure 4.3 - Gas Block

5 INSTALLATION PREPARATION AND - INSTRUCTION

The device is developed, tested and approved conform the applicable standards for the usage, the performance and safety of the product. The installation of your device must apply to the current building prescriptions. We advise to make use of a qualified gas installer for the installation of your device. The installer can provide you with all information regarding the safety regulations of the installation.

5.1 Relevant norms and guidelines

The installation must be carried out in accordance with the following regulations

- Department of the Environment, the Building Standards (Scotland) (Consolidation) Regulations issued by the Scottish Development Department.
- BS 5440 part 1
- BS 5871 part 2
- BS 6891.

In the Republic of Ireland the installation must also conform to the relevant standards, particularly in regard to flue sizing and ventilation. Refer to documents;

- IS813
- ICP3
- IS327
- Any other rules in force.

This appliance must be installed in accordance with the rules in force and used only in a sufficiently ventilated space, and is intended for use on a gas installation with a governed meter.

5.2 Attention points gas fireplace

This device can be place in a new or existing situation. The device can be installed in a fully enclosed or mechanically ventilated room without extra ventilation.

Before installation of these appliances, the area into which the fire is to be fitted must be cleared of all debris (including dust), in particular combustible material.

5.3 Attention points gas connection

The gas connection should apply to the local norms in force. Calculate the diameter of the gas flue, such that no pressure loss is occurring in the pipes. Place a shut-off valve in the near vicinity of the device. Position the gas connection, such that it is always accessible for service purposes.

Put the gas block and receiver behind the included service hatch. Make sure that it is always accessible for service purposes. (See **Figure 5-1**)

5.4 Requirements flue and wall terminals

The European CE-marking for the device is only applicable to the flue materials specified by the supplier. The device must be



Figure 5.1 - Service Hatch (BDLE4)

installed with the stainless steel flue material US by Metaloterm/ On top. The usage of other concentric stainless steel material is only permitted when it has the same technical specification as the previous mentioned systems.

Only when these materials are used a good and safe performance can be promised by Element4.

The flue channel can work both a wall terminal (C11) as a roof terminal (C31), as well as flex pipes in an existing channel. Please check, whether the desired terminal complies with the regulation for your situation (See: **APPENDIX D**).

It is possible that an extra shield is necessary when the terminal is within two meters from the ground.

5.5 The chimney

Before the chimney is installed, we advice an operation test with the device. The chimney should be constructed from non-combustible materials and cannot rest on the mounting frame. Always use a chimney iron, when using bricks or cell concrete.

The chimney ventilation should meet the the local norms. A well ventilated chimney makes sure the temperature is regulated to ensure a proper operation of the electronics and the gasblock. Furthermore, good ventilation helps to keep the convection air under 85°C. Use the ventilation grate (CVRE4) and service hatch (BDLE4) by Element4. See the measurements in **APPENDIX I**.

More on chimney construction in **THE NEXT CHAPTER**.

6 FIRE SAFE INSTALLATION

To install a gas fireplace as safely as possible, several installation preparations need to be made. This overview can be used to assure the fire safety of a conversion of a fireplace.

6.1 Fire safety device set-up

Install the device such that there are no flammable materials around the device or chimney. The device must never be placed against a back wall of flammable materials.

Flammable materials, such as wood, can combust at a temperature of 85°C. At high temperatures this can happen within several minutes (over 200°C) or at lower temperatures (more than 85°C) this may occur over a period of weeks.

A gas fireplace can achieve temperatures of over 200°C. Therefore one should use only non-flammable materials around the fireplace and in the cove.

It is important to follow the installation regulations below carefully. When the regulations are insufficiently- or not provided with the aspects of fire safety, the instructions according to NPR 3378-20:2010 are leading.

6.1.1 Protection of wall and ceiling

There are two kinds of walls/ceilings that can be distinguished, respectively;

1. Walls/ceilings that are made of – or contain flammable building materials, and all walls on which flammable objects (e.g. built-in furniture or wooden panels) are mounted on the side of the wall that is turned away from the fireplace.
2. Walls/ceilings made of mineral building materials (gas concrete, bricks, lime sandstone etcetera.) of more than 10cm thickness.

6.2 Assembly regulations

6.2.1 Assembly regulations for non-flammable materials

(Figure 6.1 and 6.2)

- Cover the walls/ceilings with a non-flammable, fire resistant plate, according to EN 13501-1:A2
- Place a non-flammable, fire resistant plate in front of the first one at a distance of 2cm.
- Make sure that the two plates are not attached to each other by screws or nails. Due to their conductivity these metals can cause problems.

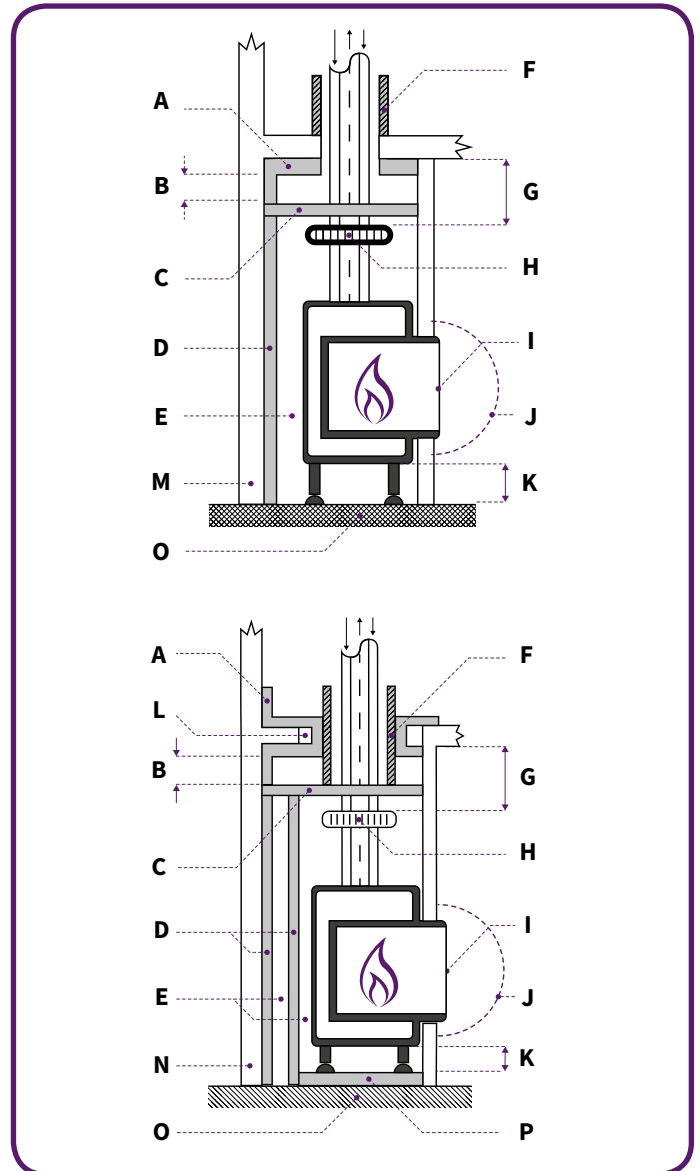

#	Description
A	Insulation (near ceiling)
B	Distance to false ceiling ($\geq 100\text{mm}$)
C	False ceiling
D	Layer of insulation
E	Distance to layer of insulation ($\geq 20\text{mm}$)
F	Casing of non flammable material
G	Distance to convection grate ($\geq 300\text{mm}$)
H	Convection grate ($2 \times 150\text{cm}^2$)
I	Outside of the fireplace ($\sim 200^\circ\text{C}$)
J	Radiation distance to flammable objects ($\geq 500\text{mm}$)
K	Distance fire to non flammable floor ($\geq 100\text{mm}$)
L	Air cavity ($\geq 50\text{mm}$)
M	Flammable wall
N	Non-flammable wall
O	Flammable floor
P	Non-flammable floorboard
Q	Non-flammable cover

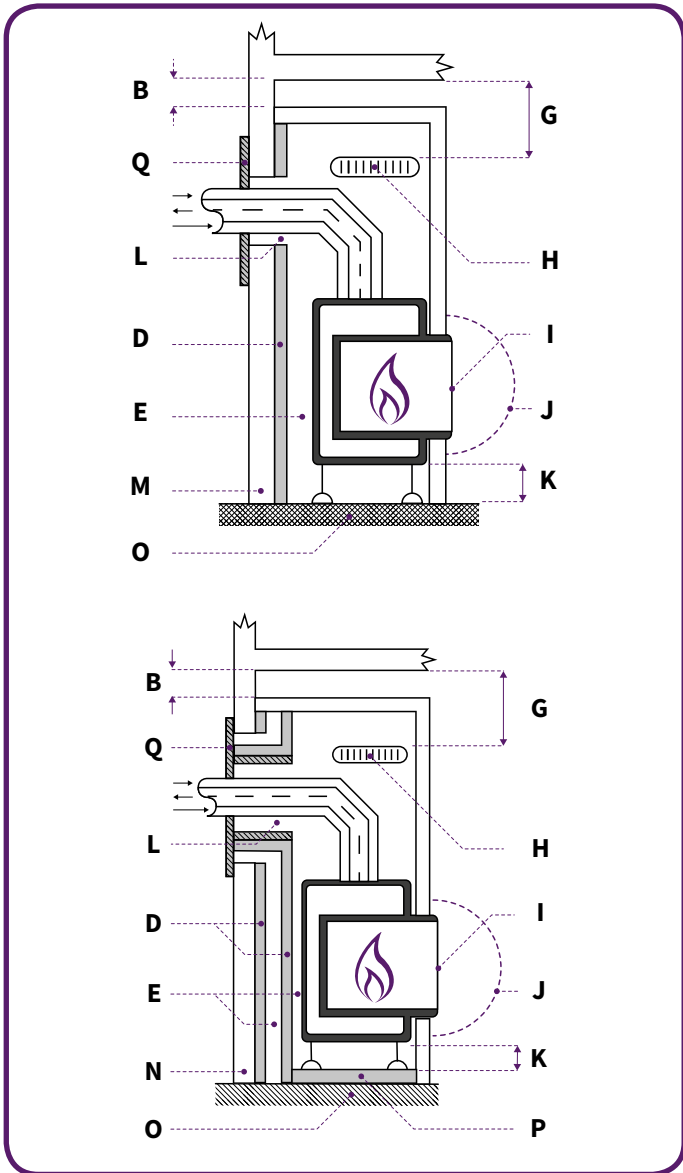

*Figure 6.2- Top Left
C31 - Flue situatie Non-Flammable material*

*Figure 6.2- Bottom Left
C31 - Flue situatie Non-Flammable material*

*Figure 6.3 - Top Right
C11 - Flue situatie Flammable material*

*Figure 6.4 - Bottom Right
C31 - Flue situatie Flammable material*

6.3 Assembly regulations with flammable materials
(Figure 6.3 and 6.4)

Load-bearing walls and ceilings must be covered in a protective fire resistant plate.

Never use flammable materials around the fireplace or cove. The minimal distance between the device and non-flammable materials must be at 50 mm to ensure a convection air flow.

Make sure there is a good air ventilation in the cove. The temperature that leaves through the ventilation grilles must not be higher than 85°C. Therefore one should always make sure there are enough ventilation grilles in the upper and lower parts of the cove.

6.3.1 Hot air outlets and ventilation grilles

The ventilation grilles are to be placed at a minimal distance of 20cm from the ceiling and 30cm from any built-in furniture from the side, any flammable material or load-bearing concrete parts. To avoid heat accumulation in the cove a non-flammable false ceiling is to be placed directly above the grilles. The ventilation grilles need to be easy to clean at all times.

6.3.2 Floor protection

Between the device and the ground a minimal distance of 10cm is to be taken into account. The temperature of the floor under the device needs be less than 85°C and the floor of the conversion around the fireplace is to be constructed of non-flammable materials. If necessary the floor is to be covered with an insulation layer to protect it from unauthorized temperatures.

6.3.3 Radiation

When the fireplace is turned on, heat radiation will escape through the ceramic glass and will heat up the environment. Therefore it is important that a minimal distance between the ceramic glass and any flammable material in front of the fireplace is 40cm.

6.3.4 Electrical pipes

The conversion has to be free of the usual electric installation pipes, if these are not protected against temperatures over 30°C by the necessary precautions. Special pipelines with an heightened heat resistance are permitted.

7 ATTENTION POINTS GAS FLUE

To guarantee the fire safety regarding you flue gas configuration a casing is necessary. For this case non-combustible materials should be used. Make sure to ventilate a shaft and never to insulate it, to make sure the hot air is able to get away.

Every transit or terminal should be made such, that the warmth-insulation and non-combustability is guaranteed, according to the building regulation.

7.1 Installation of flue material

Follow the following instructions for the installation of flue materials;

- Drill a hole of 160 mm for the wall or roof transit with a 150 mm diameter flue connection, and 210 mm with a flue with a diameter of 200 m.
- Keep a distance of at least 50 mm between the outside of the concentric pipes and the wall or ceiling.
- Provide a (fire) safe transit construction in wall, floor or roof sheeting
- Build the system from the fireplace.
- Assemble pipes in the correct direction! The inner pipe goes into and the outer pipe goes over the fireplace connection.
- Make sure the tubes are sufficiently braced, so the weight of the tubes are not supported on the hearth.
- The concentric pipes could come loose due to expansion and cooling down. It is recommended that a chuck parker be used in places that are inaccessible after installation.
- The horizontal drain portion must be fitted sloping to the hearth.

7.1.1 Adapting the length of the chimney

Not all parts can be adjusted! To fit the drainage system correctly, you are to use an adjustable fitting. You can use an adjustable concentric pipe, wall or roof fitting. To get a sealed flue gasconnection, the inner pipe must always be 2 cm longer than the outer pipe. Always attach adjustable parts with a chuck.

7.1.2 Calculate chimney

For proper operation of the fireplace it is important that the flue pipe meets the requirements. Do determine this, we prepared a calculation chart. (See **APPENDIX E & F**)

8 INSTALLATION CHECK AND FIRST USAGE

8.1 Renovation/new construction

When firing up the device for the first time, make sure the device burns for several hours on the highest level, to ensure the lacker to harden. Make sure the device is ventilated enough so the possible released fumes are being abducted. We advice to be as little in the room as possible during this process.

Because a fireplace is a heat source, natural convection will occur around it. Solid particles in the circulating air may burn and settle down on cold surfaces, causing discoloration. Discoloration is an annoying problem and it is difficult to solve.

These particles can come from construction moisture or cigarette smoke, but also they might be volatile components in paint, construction materials or carpeting. For newly constructed chimneys or after a big reconstruction, it is advised to wait a minimum of six weeks before firing a fireplace.

8.2 Checking the gas lines

To be able to check on the gas lines, it is necessary to have the right equipment. If necessary take out the glass of the device and use the measuring point (see **figure 8.1**), to check the supply pressure on the gas pipes.

A = Supply pressure
B = Burner pressure

Make sure the cables of the ignition are hanging loosely under the device, to ensure a good ignition. Remove any tie wraps or other cable binders.

Check the pilot and second thermocouple for obstructions and check the air tightness of the system. Technical specifications can be found in **APPENDIX G**.

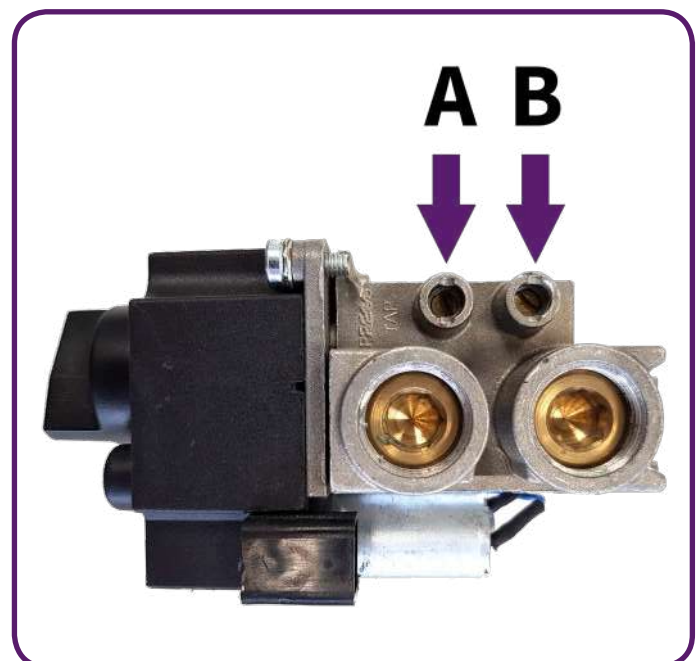

Figure 8.1 - Gas Block Measuring Points

9 ELECTRICAL CIRCUIT

Figure 9.1 shows a simplified connection circuit for the fireplace. Every fireplace is provided with a main adapter. The Element4 Club Series comes with the WifiBox as a standard feature, giving the user full control of the fire via a smart device.

#	Omschrijving
(1)	Gas Block
(2)	Receiver
(3)	Main burner
(4)	Pilot set
(5)	Second thermocouple
(6)	6V Adapter
(7)	Wifi-Box
(8)	Transformer and powersupply LEDs
(9)	LED strips

9.1 Element4 ProControl App.

The Element4 Club Series offer the possibility to operate your device via smartphone or tablet with the ProControl App, available in the appstore on iOS and google play on Android.

The app has a user friendly, interactive layout and the design is adjusted for Element4 devices. Up to eight devices can be used with one app, in the situation that multiple fire are installed in the same location.

Another functionality of the app is to pre-set the temperature of you device, for a period of one week, to ensure yourself of an optimal desired room temperature. Also the device can be changed between high and low flames and it features an eco-setting.

The Club Series offers the possibility to change the colour of the fire bed, next to the standard options already available on the ProControl app. Via the app, one has a range of solid colours or varying special colour patterns to choose from.

The amount of users, that can operate the device is unlimited, so every family member can make use of it, by easily making a personal account. By two-way communication, one can check on the device at any moment.

To use the app, the device needs to be provided with the correct receiver and remote combination and also the receiver should be connected to net electricity with a 220V adapter, which will replace the batteries.

Necessities for the installation of the ProControl:

- 220 volt electricity near the fire
- Wi-Fi code of the router
- Smart Phone or tablet
- ProControl manual

Should any problems occur you can always check **APPENDIX B** or check the usermanual or the app itself under the information menu, marked with a lower case "i".

9.2 Domotica

The receiver offers the possibility to be connected to a domotica system. A special connector is being supplied for this. Type: G60-ZCE

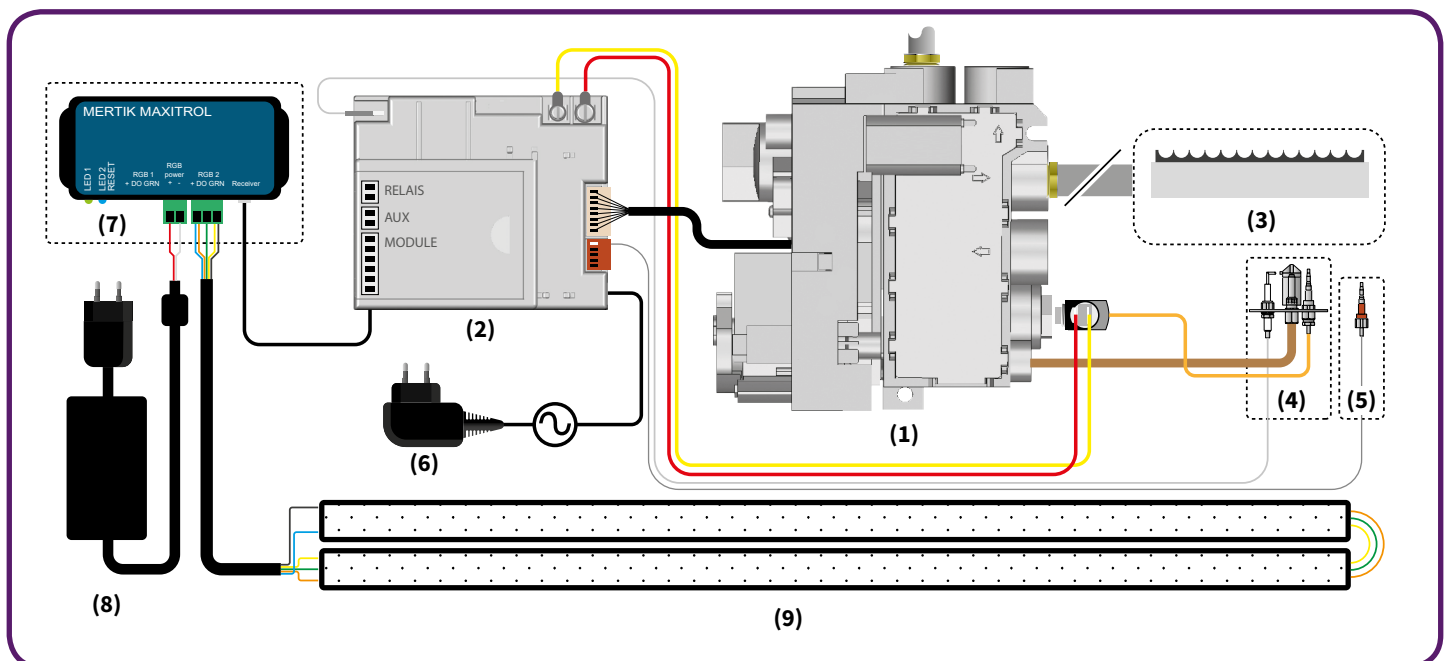

Figure 9.1 - Schematic Electronic Circuit

10 MAINTENANCE INSTRUCTION

This part of the manual focuses on maintenance. To ensure the optimal flame picture of your device, an annual maintenance by a competent company or installer is prescribed.

10.1 Maintenance in the combustion chamber

Please note:

The following steps are only applicable to the Club 140 Front, corner and threesided models. For the Club 140 Room Dividers and Tunnel models please see the next pages.

During maintenance the glass windows of the fire need to be removed. To do this follow the following steps:

Front, Corner and Threesided models:

10.1.1 (Dis)assembly of the trims

For a tight finish of the fireplace, trims are available. During maintenance these trims must be removed, before the glass can be removed. Please follow these steps:

Disassemble

- Remove both the side trims and bottom trim. They are held by magnet snappers, **Figure 10.2 & 10.3**.

Assembly:

- Put the trims back in reversed order.

10.1.2 Remove glass

To be able to clean the glass on the inside, one needs to remove the glass. To do this follow these steps:

- Check, whether the trims are removed in as in **step 10.1.1**.
- Remove the glass cords. (See **Figure 10.4**)
- Put the section cup on the glass and make sure it is properly vacuumed, so it will not come off. (See **Figure 10.5**)
- Lift the glass out of the lower glass rail and tilt it out through the opening, as seen in **Figure 10.6**.

NB: Put away the glass in a safe place, when you are not using it, to make sure it will not damage during maintenance. Remove the suction cup after putting away the glass to avoid tracing or stains.

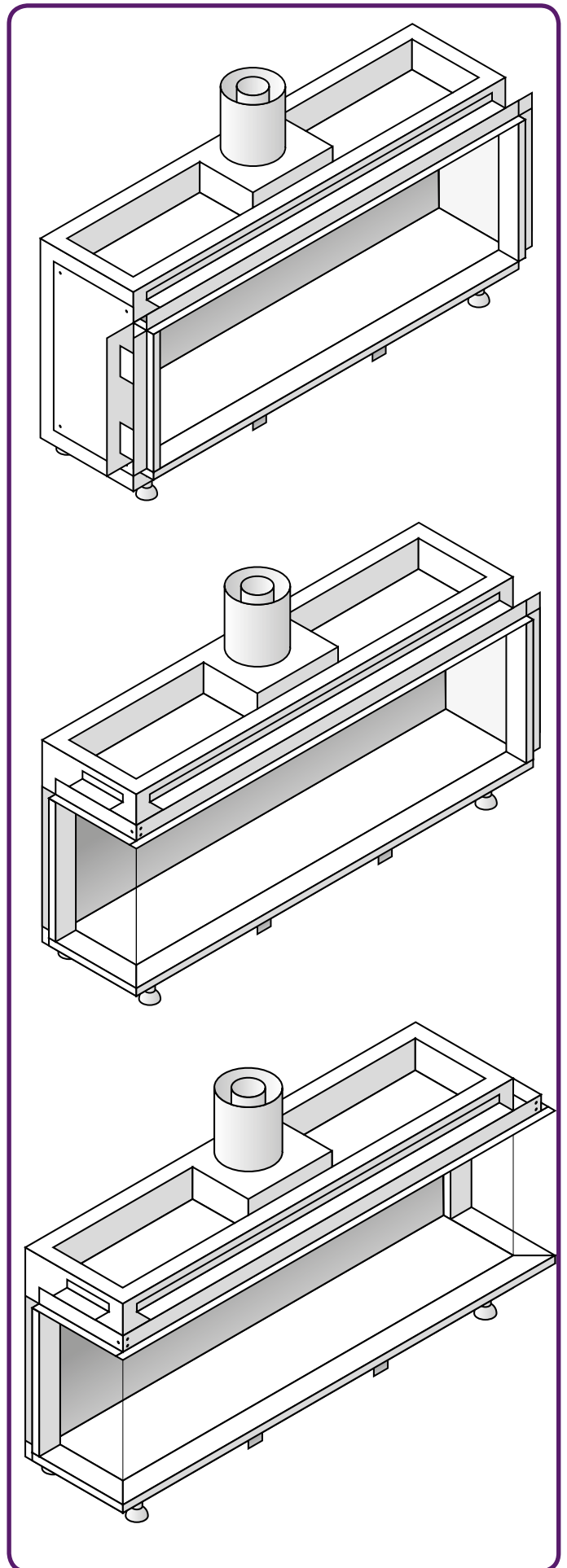

Figure 10.1 - Trisore-, Bidore- & Modore 140

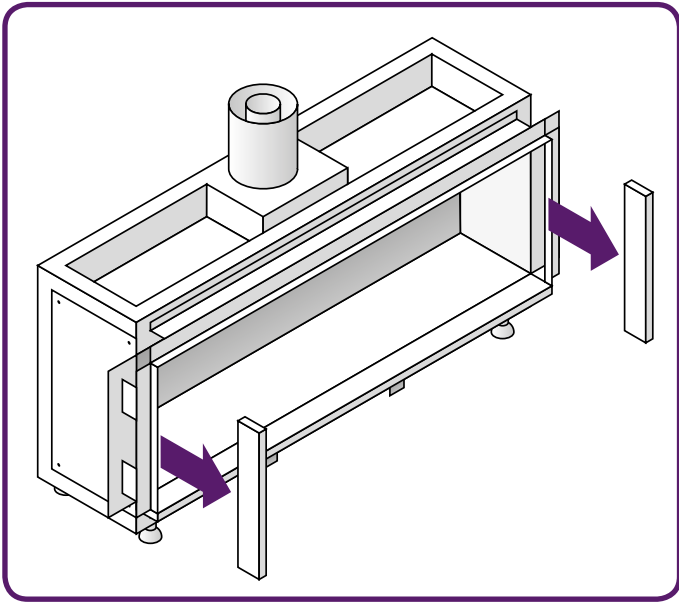

Figure 10.2 - Remove side trims

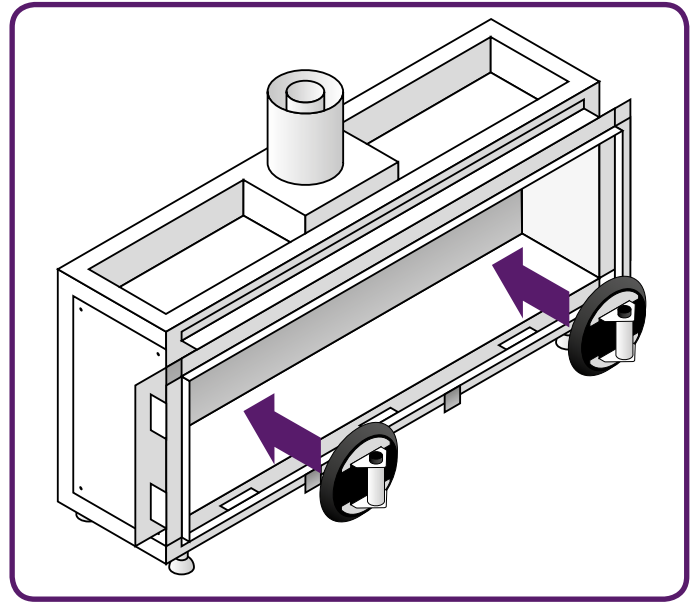

Figure 10.5 - Using the suction cup

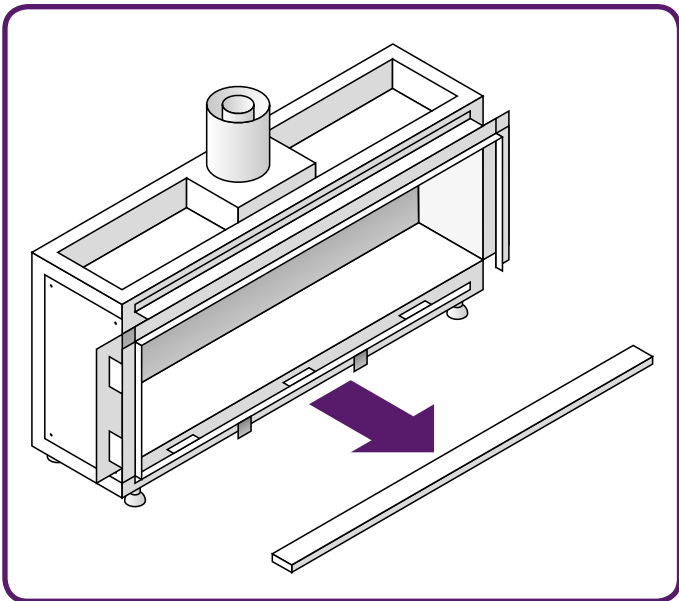

Figure 10.3 - Remove Lower Trims

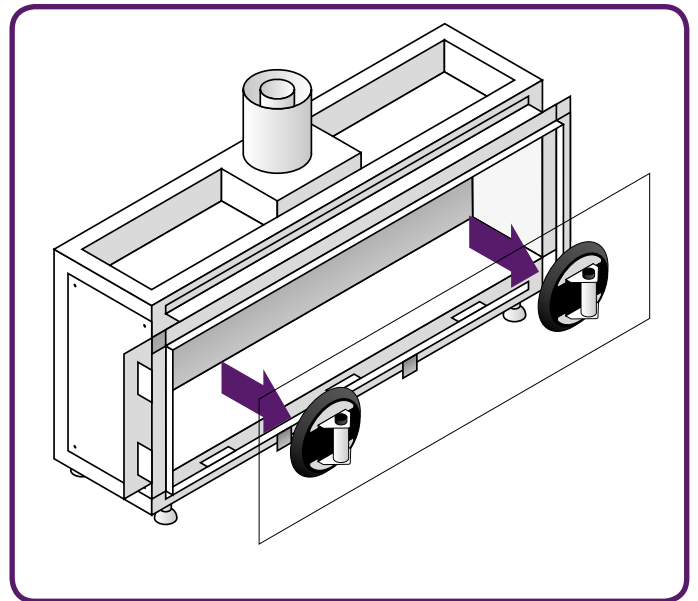

Figure 10.6 - Removing the suction cup

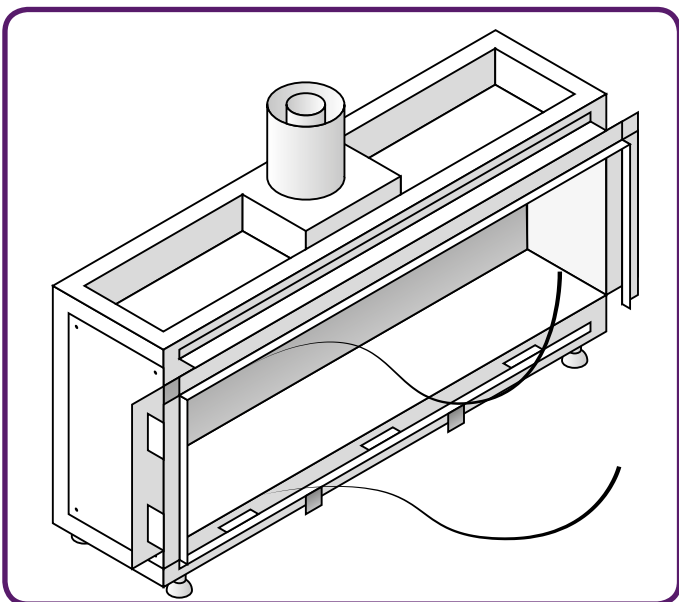

Figure 10.4 - Removing Glass Cords

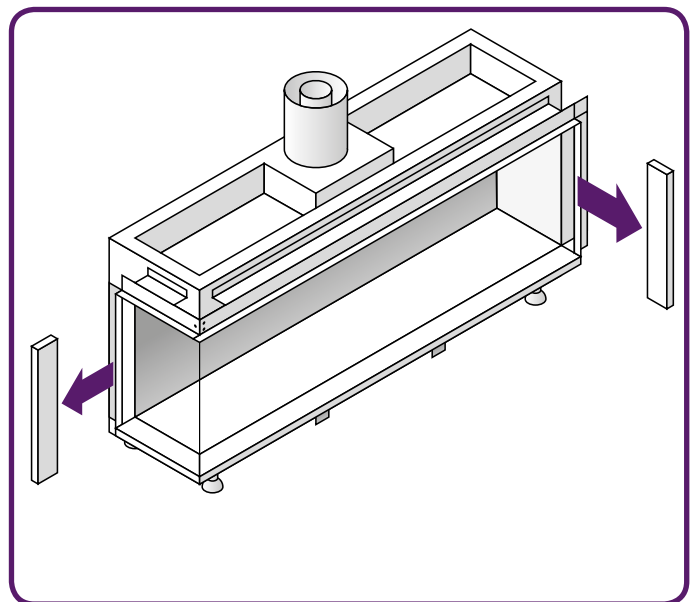

Figure 10.7 - Removing side windows (when necessary)

Room divider and tunnel models

10.1.3 (Dis)assembly of the trims

For a tight finish of the fireplace, trims are available. During maintenance these trims must be removed, before the glass can be removed. Please follow these steps:

Disassemble

- Remove both the side trims and bottom trim. They are held by magnet snappers, **Figure 10.9 & 10.10**.

Assembly:

- Put the trims back in reversed order.

10.1.4 Remove glass

To be able to clean the glass on the inside, one needs to remove the glass. To do this follow these steps:

- Check, whether the trims are removed in as in **step 10.1.1**.
- Remove the glass clamps. (See **Figure 10.11**)
- Put the section cup on the glass and make sure it is properly vacuumed, so it will not come off. (See **Figure 10.12**)
- Lift the glass out of the lower glass rail and tilt it out through the opening, as seen in **Figure 10.13**.

NB: Under no circumstance may the head glass of a Lucius 140 be removed from the fireplace, for this will cause the fire to collapse. Only remove this glass panel when transportation brackets are still in place / are repositioned.

10.2 Cleaning the glass

Keep in mind the following when cleaning glass:

- Always clean the glass at room temperature.
- Use cleaning supplies qualified by Element4.
- When you clean your Anti-Reflective glass, make sure you use this with the special Element4 cleaner, which is available only via Element4.
- Use only a microfibre cloth. Other materials such as kitchen towels, steel wool etcetera can cause scratches or damage the coating on the glass.
- Should there occur stains on the glass, remove them regularly, for the can burn the glass.

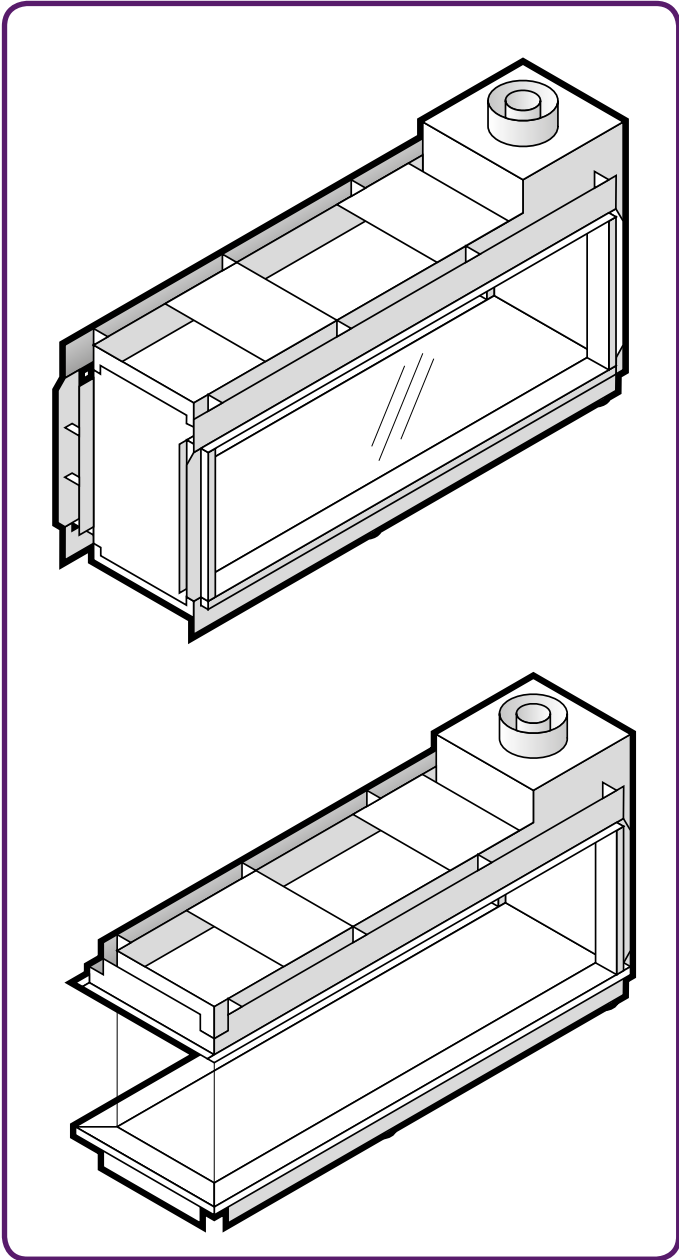

Figure 10.8 - Lucius- & Tenore 140

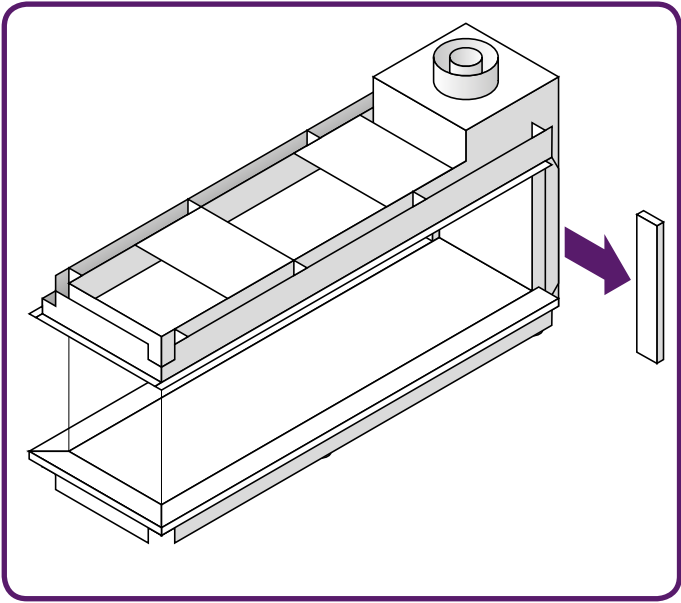

Figure 10.9 - Remove side trims

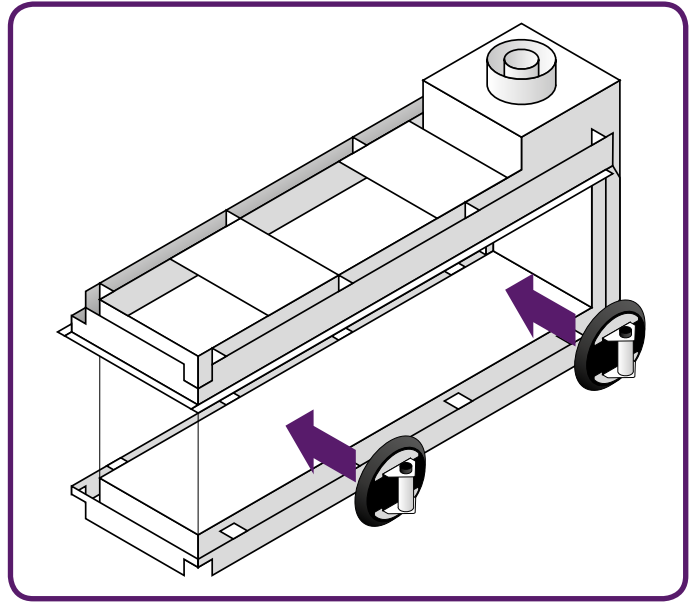

Figure 10.12 - Put on the suction cup

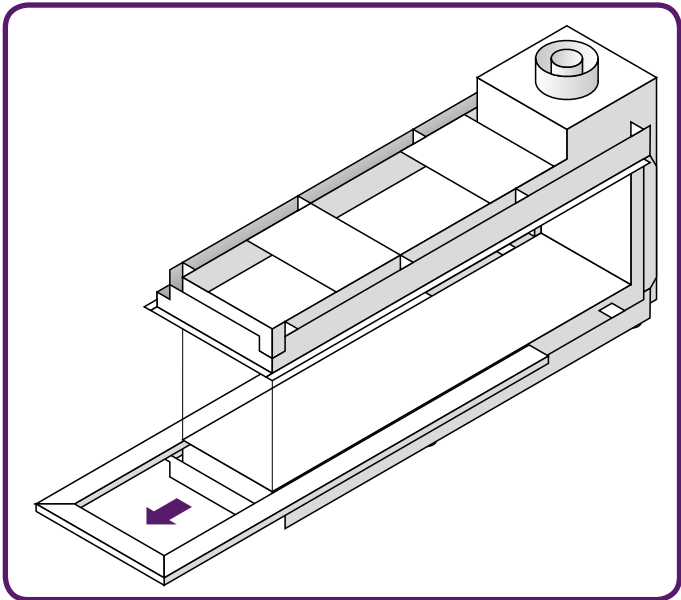

Figure 10.10 - Remove bottom trim

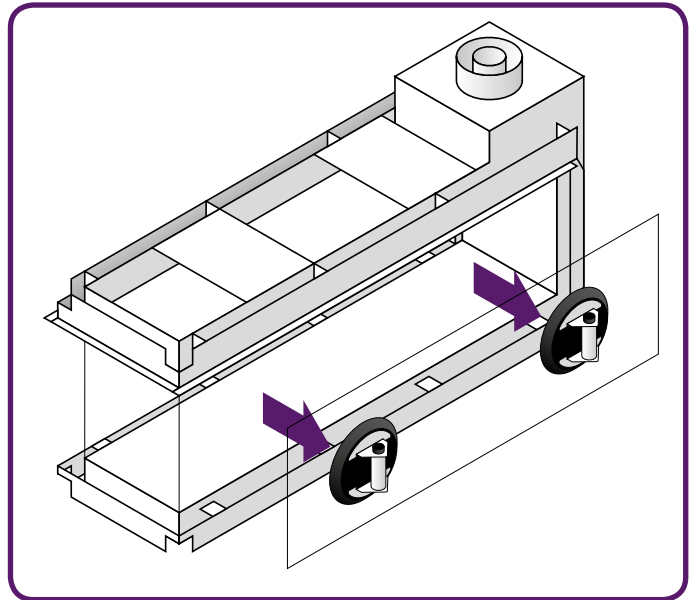

Figure 10.13 - Remove glass

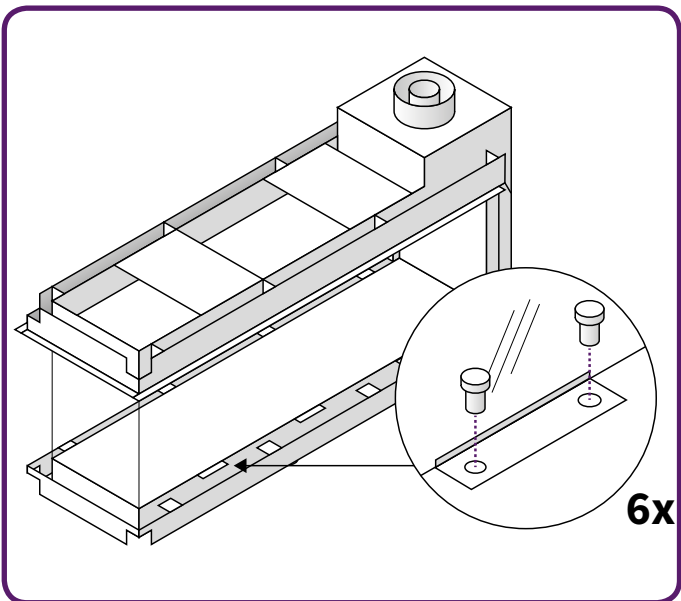

Figure 10.11 - Remove glass clamps

11 PLACING THE DECORATION MATERIAL

Every fireplace in the Element4 Club Series is equipped with a very thin ribbon burner for a maximum light effect. To ensure that the light is spread evenly over the burner bed, place the decorative material (as shown in **Figure 11.1**) in the appropriate trays. Ensure that a proportional layer of glass is spread over the burner grate.

Note: The decorative material may be placed against the ribbon burner, but there must never any decorative material above the burner!

Finally check that the pilot flame and the tip of the second thermocouple are free of glass. By expansion of the fireplace under heat, glass can easily reach the flame and the second thermocouple.

In the most serious case, multiple layers of glass can block the safety mechanisms in the fireplaces or stifle the fire image.

Too thick a layer of decorative material can also disrupt the air in the fireplace and Element4 can no longer guarantee optimal flames.

Too much or improperly placed decorative material will adversely affect the fire image and can ignite the fire with a "thud"!

Finally, before replacing the glass panel, first briefly test whether the ignition works properly.



Figure 11.1 - Decorationmaterial for the Club 240

12 LED-LIGHTING

As already briefly mentioned in **CHAPTER 9**, the Element 4 Club Series can be operated with the ProControl app.

This means that the remote or Puck (see **Figure 12.1**), which is supplied as standard with the fire, can only be used to start the fire and to raise / lower the fire image.

12.1 Function of the handheld transmitter for the Club Series

For the remote, all its functions, such as the ecowave, can be used, but the ProControl app provides a more extensive range of options for the same functionalities.

Note: A remote control or Puck must be present at all times near the appliance in order to switch off the fire in an emergency.

12.2 LED ports

A WifiBox is supplied as standard with every fireplace in the Club Series. This WifiBox has one or two LED ports, to which the LED strips that are located under the fireplace are connected. The LED strip of the fireplace is connected as standard to port 1.

If desired, a second LED strip can be connected to port two. This LED strip is individually controlled in the ProControl app and can be used as ambient lighting.



Figure 12.1 - Remote and puck

13 USER INSTRUCTION

We recommend that you have the appliance inspected annually by a recognized installer to ensure safe use and a long service life guarantee

13.1 Hand over to the customer

- User manual
- Installation manual
- Instruction card decoration material
- Suction cups
- Remote control

13.2 Maintenance instructions for the installer

Below is an overview of the minimum maintenance that must take place annually;

- Remove the glass plate and remove all ceramic parts.
- Remove any dirt on top of the burner with a vacuum cleaner and brush.
- Inspect the burner.
- Perform an ignition check.
- Check that the pilot light ignites the main burner free and unhindered by decoration material.
- Perform a flame failure check

Maintenance on the burner should not be necessary. If this is the case, check the set pressure at the inlet to the burner. The correct pressure is stated in the back of this manual.

Next:

- Check the state of the decoration material, replace parts when necessary.
- Check the ceramic cord on the glass plate
- Reinstall the glass plate.
- Check the installation for gas leaks.
- Check whether the roof- / wall terminal is free of obstacles.

13.3 Anti-reflective glass

Anti-reflective glass for the gas fireplaces consists of polished ceramic glass on which metal oxide coating layers have been applied. The thickness of the coating is checked down to the nanometer to perfectly control the reflection level. The reflectance level of untreated glass is on average 8%, while an anti-reflective glass provides a reflection of only 0.7%. Thanks to the new coating technology, anti-reflective glass is completely invisible when approached straight ahead. This gives the gas fireplace a super realistic fireplace effect. In this way you use all the advantages of a gas fire, while the atmosphere and warmth nevertheless match the fireplace.

Maintenance of anti-reflective glass for anti-reflective windows is of great importance to observe certain maintenance instructions. In order not to damage the coating layers, the use of hard (sanding) sponges, abrasives and cleaning agents with ammonia is prohibited. Only use a neutral cleaning product (neither acidic nor alkaline), such as Element4 window cleaner

(Item No. 4500926). The cleaning agents that you normally use should therefore not be used with an anti-reflective glass. Use a soft cloth or sponge (not paper).

Just as with ordinary ceramic glass, the white haze that results from the first combustion must be removed with anti-reflective glass. After that, sporadic maintenance is sufficient. Always rub the window completely dry: Residual water can stain the coating. Fingerprints are more visible on anti-reflective glass, therefore wear (rubber) gloves when grasping the window. If the window is lifted with a suction cup, the rubber of the suction cup must be dry to avoid damage to the coating.

13.4 Replacement of parts

If parts need to be replaced, use only original parts from the manufacturer. The warranty will be void if non-standard parts are used. In addition, they can be dangerous.

13.5 Packaging materials

The packaging of the device is recyclable. The following packaging materials may have been used:

- Cardboard
- CFC-free foam (soft)
- Wood
- Plastic
- Paper

These materials must be disposed of in a responsible manner and in accordance with government regulations.

Batteries are regarded as chemical waste. The batteries must be disposed of in a responsible manner and in accordance with government regulations. Remove the batteries first before discarding the remote control.

The government can also provide information about the responsible disposal of discarded appliances.

A FIRST AID FOR MALFUNCTION

Below you will find an overview of the possible cause and solution in the event of a failure.

Problem	Possible Cause	Solution
A No transmission (motor will not run)	1 Batteries in the receiver empty	Replace the batteries (4x 1.5V AA)
	2 Batteries hand remote empty	Replace the batteries (2x 1.5V AAA)
	3 6V-adapter defective	Check the adapter Replace the adapter if necessary
	4 Hand transmitter not linked to the receiver	Connect the hand transmitter to the receiver Press and hold the reset button until you hear two beeps. After the second longer tone, release the reset button. Press within 20 sec. on the down arrow on the hand transmitter Two short beeps confirm that the code has been set. Tip: For this action a video is available on our youtube channel
B Receiver does not receive a signal	1 Receiver defective	Replace receiver
	2 Bend pin connection on the receiver	Bend the pen straight again (See Figure A.1)
	3 Hand transmitter defective	Replace the hand transmitter
	4 No or bad reception. The receiver is in a metal box! This disturbs the reception.	Change the position of the antenna (See Figure A.2)
C No ignition; no beep	1 Receiver defective	Reset the receiver (See K1) If necessary, replace the receiver
D No ignition; receiver gives a five-second beep	1 Loose contact in the thermocouple circuit / wiring 2nd thermocouple	Check plug connections Repair the wiring if necessary
	2 Receiver defective	Replace receiver
	3 Magnetic coil defective	Replace gas block / or only coil coil
	4 Bent pin connection on the receiver	See B2
	5 Thermocouple broken	Check the thermocouple at the bottom of the pilot burner if necessary. fracture. Replace the thermocouple if necessary
E Ignition stops after 1 spark	1 Mass on the gas block not OK	<ul style="list-style-type: none"> • Remove the 20mm Torx screw (See Figure A.3) • File or scrape the surface thoroughly • Reinstall the Screw and tighten it securely Tip: For this action a video is available on our youtube channel
F No pilot flame but there is an ignition	1 No gas	Check / measure gas inlet pressure
	2 Air in the gas line	Venting the gas line can be done via test point A (Figure A.4) Tip: For this action a video is available on our youtube channel
	3 Pilot flame blocked	Check pilot burner
	4 Thermocouple wiring is incorrect	Check the wiring on the interrupter (See Fig. A.5) Check the wiring on the receiver (See Fig. A.6)

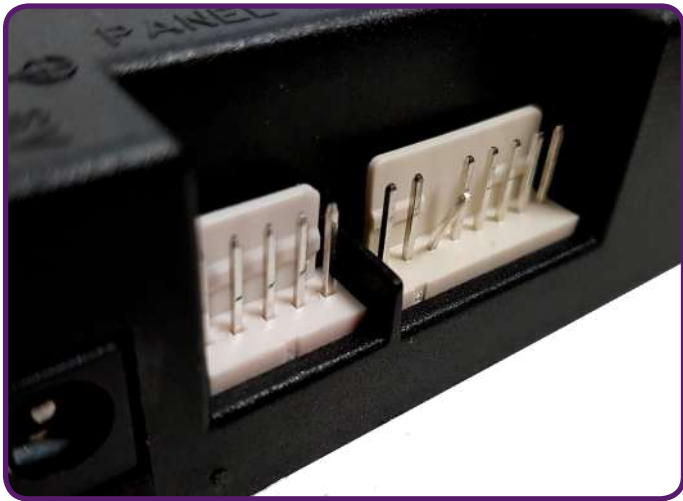

Figure A-1: Bend pin



Figure A-4: Testpoint A

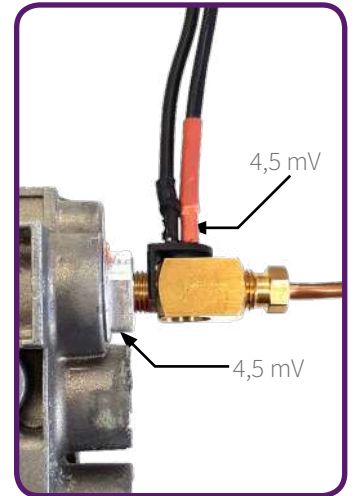

Figure A-5: interrupter

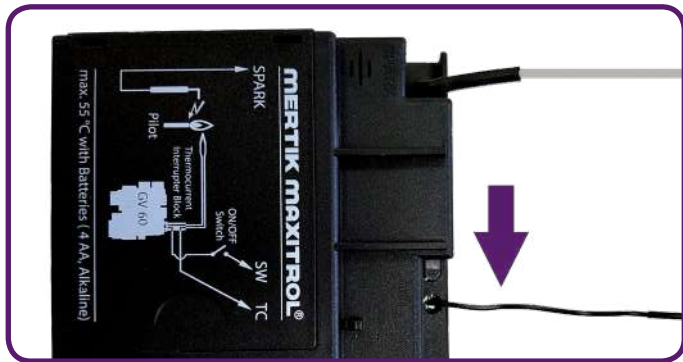

Figure A-2: Antenna

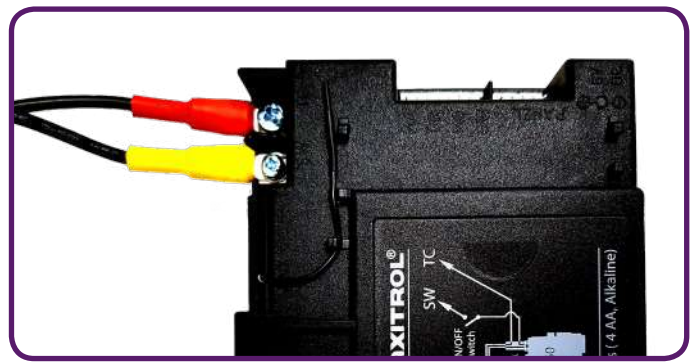

Figure A-6: Wiring receiver



Figure A-3: Torx screw

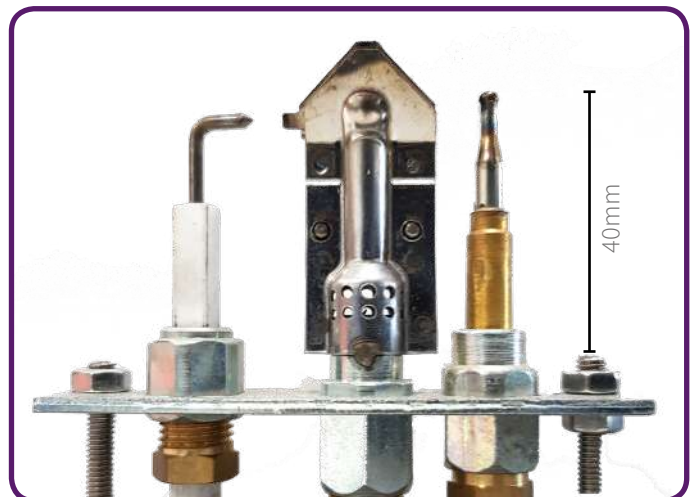

Figure A-7: Pilot set

APPENDICES

Problem	Possible Cause	Solution
G The pilot light goes on but goes out immediately when the main burner switches on	1 Insufficient voltage across the thermocouple or too much resistance in the thermocouple circuit	Place the measuring pins of the multimeter on the ground and black cable of the breaker. This value must be at least 4.5 mV. Tip: For this action a video is available on our youtube channel
	2 Gas pressure loss may cause the pilot flame to be too small	Check and measure the pre-pressure via test point A (See Figure A.4) Tip 1: Measure the pre-pressure load and unloaded Tip 2: For this action a video is available on our youtube channel
	3 Thermocouple defect	Replace thermocouple Tip: Always use a new pressure piece when a thermocouple is replaced
	4 Thermocouple is incorrectly positioned	Check the position of the second thermocouple. (See Figure A.7)
H Check the position of the second thermocouple. (See Figure A-7)	1 Decoration material blocks 2nd thermocouple	Leave the space around and at the 2nd thermocouple free of decorative material. (See Figure A.8)
	2 Burner grille does not fit well with the 2nd thermocouple	Position burner grate
	3 Airflow in the burner chamber causes a restless fire image	Check drain configuration Fit a flue gas limiter
I Receiver gives 3 short beeps after each command:	1 Batteries in the receiver are empty	Replace the batteries 4x 1.5V AA
J Pilot is on but the main burner does not start working:	1 Gas valve is on manual	Set Knob A must be in the ON position
K Double burner does not work:	1 RESET the receiver	Briefly press the RESET button and the receiver sounds 1 beep (See Figure A.10)
	2 Wiring loose on the receiver	Click the plug in the AUX position on the receiver. (See Figure A.11)
	3 Solenoid valve does not switch	Replace the solenoid valve. Tip: Only connect a new valve to the receiver first
	4 Remote defective.	Check if the AUX symbol is on the display when you press the PLUS PLUS key on the remote. (See Figure A.12)
L No response from the receiver when the fireplace is started via smartphone or tablet.		Disconnect the Wi-Fi box from the receiver Click the plug from the SI connection on the receiver (See Figure A.13) Tip: Reset the home router If the fireplace now functions normally, check the Wi-Fi settings
M Hearth does not respond via Domotica system		Disconnect the cabling on the Domotica system and start the fire with the hand transmitter When the fireplace now reacts normally, the problem is in the Domotics

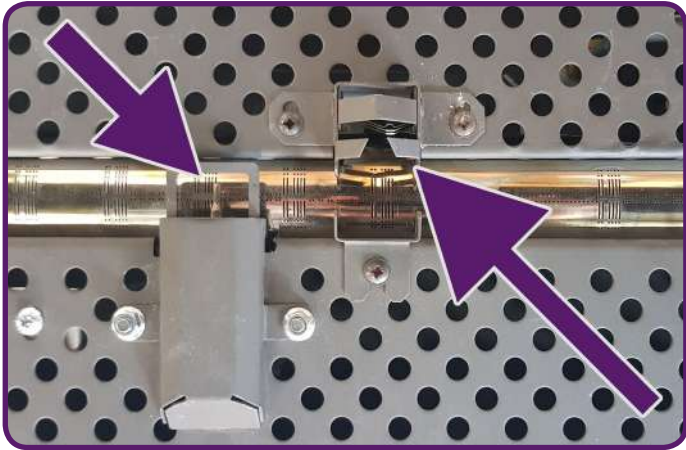

Figure A.8: Second thermocouple

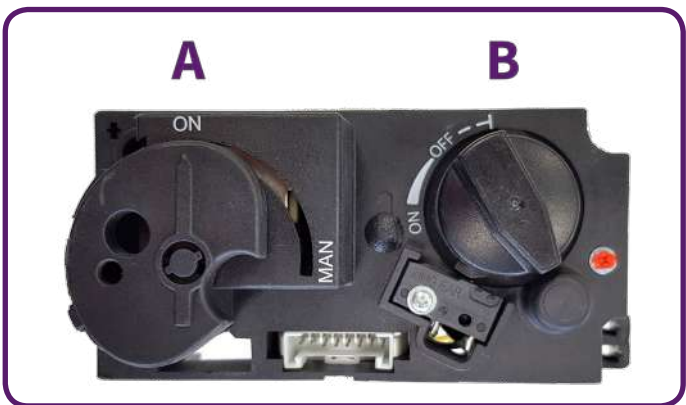

Figure A.9: Button A on "On"



Figure A.10: RESET-button



Figure A.11: Aux-position receiver



Figure A.11: "Double plus"-button on the remote



Figure A.13: SI-port

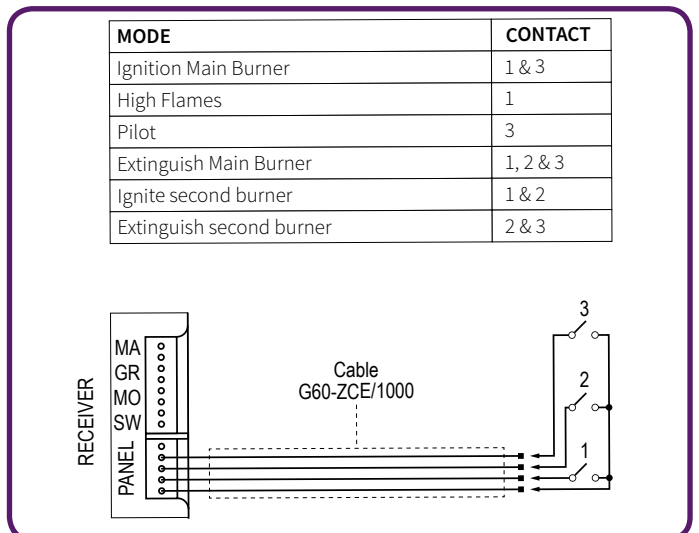

Figure A.14: Domotica system

APPENDICES

B ERRORS CODES PROCONTROL APP

B.1 Messages shown in app

Error code	Message in App	Description	Possible cause
F02	Contact Service.	<ul style="list-style-type: none"> 5 sec. beep from Receiver Fire is not responding; no ignition 	<ul style="list-style-type: none"> Microswitch not making contact with cam on motor knob Motor wiring is incorrect Reversed polarity or faulty Microswitch Bent Motor Knob
F03	Contact Service.	<ul style="list-style-type: none"> 5 sec. beep from Receiver Ignition process is interrupted Fire is not responding; no ignition 	<ul style="list-style-type: none"> Thermocouple wiring is incorrect Thermocouple wiring is not connected ON / OFF switch in O (OFF) position
F04	Ignition Sequence Malfunction. Wait 1 minute. Retry ignition.	<ul style="list-style-type: none"> No pilot flame within 30 sec. NOTE: After 3 failed ignition sequences F06 shown 	<ul style="list-style-type: none"> No gas supply Air in pilot supply line No spark Reversed polarity in thermocouple wiring Check for correct pilot orifice (LPG to NG or vice versa)
F05	Contact Service.	<ul style="list-style-type: none"> Pilot burner fails to ignite or shuts off Motor stays in pilot position 	<ul style="list-style-type: none"> Not enough thermo-voltage Air in the pilot supply line Low inlet pressure Bad thermocouple
F06	Contact Service.	<ul style="list-style-type: none"> 3 failed ignition sequences within 5 minutes Fire is not responding; no pilot flame 	<ul style="list-style-type: none"> No gas supply Air in pilot supply line No spark Reversed polarity in thermocouple wiring Check for correct pilot orifice (LPG to NG or vice versa)
F07	Replace Handset Batteries.	<ul style="list-style-type: none"> Battery icon flashes on handset display 	<ul style="list-style-type: none"> Low battery power in handset
F08	Contact Service.	<ul style="list-style-type: none"> Low Receiver battery power supply Short beeps for 3 sec. during motor turn 	<ul style="list-style-type: none"> Low Receiver battery power supply
F10	Contact Service.	<ul style="list-style-type: none"> Pilot lit Main burner fails to ignite and pilot shuts off Ignition is blocked for 2 minutes 	<ul style="list-style-type: none"> 2nd thermocouple is out of position 2nd thermocouple wiring is incorrect Gas logs out of position Gas ports for burner are blocked
F12	Contact Service.	<ul style="list-style-type: none"> Motor turns to pilot position 	<ul style="list-style-type: none"> Receiver powered by batteries and Receiver temperature exceeds 60 °C Check air circulation and heat shield
F13	Contact Service.	<ul style="list-style-type: none"> Motor turns to pilot position Fan at level 4 for 10 minutes (T > 80 °C) 	<ul style="list-style-type: none"> Receiver temperature exceeds 80°C Check air circulation and heat shield
F14	Contact Service.	<ul style="list-style-type: none"> 5 sec. beep from Receiver Fire is not responding; no ignition 	<ul style="list-style-type: none"> Receiver software doesn't support a 2nd thermocouple Wrong Receiver
F15	Contact Service.	<ul style="list-style-type: none"> 5 sec. beep from Receiver Fire is not responding; no ignition 	<ul style="list-style-type: none"> 2nd thermocouple wiring is incorrect 2nd thermocouple wiring is not connected
F16	Handset out of range.	<ul style="list-style-type: none"> No temperature shown in App 	<ul style="list-style-type: none"> Handset out of range for more than 1.5 h Electrical interference
F17	Contact Service.	<ul style="list-style-type: none"> Fire is not responding; no ignition 	<ul style="list-style-type: none"> Inlet voltage exceeds 7.25 V Malfunction of Mains Adapter
F18	Contact Service.	<ul style="list-style-type: none"> Switch panel / touch pad not functioning 	<ul style="list-style-type: none"> Switch panel / touch pad is locked Short in cable or button
F19	Contact Service.	<ul style="list-style-type: none"> Pilot drops when Motor opens main gas 	<ul style="list-style-type: none"> Insufficient thermo-voltage Thermocouple malfunction Low inlet gas pressure Improper thermocouple flame impingement Carbon build-up on thermocouple Valve malfunction Resistance in thermocurrent circuit
F26	Contact Service.	<ul style="list-style-type: none"> It is not possible to increase flame height after ignition Fan at level 4 for 10 minutes (T > 80 °C) 	<ul style="list-style-type: none"> Receiver powered by batteries and Receiver temperature exceeds 60°C Receiver powered by mains power and Receiver temperature exceeds 80°C
F27	Contact Service.	<ul style="list-style-type: none"> Fire is not responding No electronic control of fire 	<ul style="list-style-type: none"> No handset or Wi-Fi Box connected to Receiver for more than 3 hours
F28	On-Demand Pilot	<ul style="list-style-type: none"> Pilot shuts off after a predefined time 	<ul style="list-style-type: none"> Pilot shuts off after no motor movement for a predetermined time

APPENDICES

Error code	Message in App	Description	Possible cause
F31	Contact Service.	<ul style="list-style-type: none"> Fire is not responding No electronic control of fire 	<ul style="list-style-type: none"> Receiver or Wi-Fi Box malfunction Connection cable from Receiver to Wi-Fi Box defective
F41	Check Wi-Fi	<ul style="list-style-type: none"> Fire is not responding No electronic control of fire 	<ul style="list-style-type: none"> No Wi-Fi connection to myfire Wi-Fi Box, router and / or smart device Wi-Fi in smart device is deactivated
F42	Check Wi-Fi	<ul style="list-style-type: none"> Fire is not responding No electronic control of fire 	<ul style="list-style-type: none"> No power to router No Wi-Fi connection to router and / or smart device Smart device not in the correct home network
F43	No Receiver Connected. Contact Service.	<ul style="list-style-type: none"> Fire is not responding No electronic control of fire 	<ul style="list-style-type: none"> No communication between Receiver and myfire Wi-Fi Box
F44	Contact Service.	<ul style="list-style-type: none"> No temperature shown in App N.a. (not applicable) displayed in App 	<ul style="list-style-type: none"> Handset not within range Low battery power in handset
F49	Contact Service.	<ul style="list-style-type: none"> No electronic control of fire 	<ul style="list-style-type: none"> Receiver software < 8.32 is not supported by myfire Wi-Fi Box Version 2
F50	Contact Service.	<ul style="list-style-type: none"> No electronic control of fire 	<ul style="list-style-type: none"> Handset software < SW 231 is not supported by the myfire Wi-Fi Box Version 2

B.2 Messages shown in remote

Error code	App Message	Time	Description	Possible Cause
F04	F04	4 sec.	<ul style="list-style-type: none"> No pilot flame within 30 sec. NOTE: After 3 failed ignition sequences F06 shown 	<ul style="list-style-type: none"> No gas supply Air in pilot supply line No spark Reversed polarity in thermocouple wiring
F06	F06	4 sec.	<ul style="list-style-type: none"> 3 failed ignition sequences within 5 minutes Fire is not responding; no pilot flame 	<ul style="list-style-type: none"> No gas supply Air in pilot supply line No spark Reversed polarity in thermocouple wiring Check for correct pilot orifice (LPG to NG or vice versa)
F07	F07	Until batteries replaced	<ul style="list-style-type: none"> Battery icon flashes on handset display 	<ul style="list-style-type: none"> Low battery power in handset
F09	F09	4 sec.	<ul style="list-style-type: none"> Fire is not responding No electronic control of fire 	<ul style="list-style-type: none"> Down arrow button was not pressed during pairing Receiver and handset are not synced
F46	F46	4 sec.	<ul style="list-style-type: none"> Fire is not responding Intermittent response No electronic control of fire 	<ul style="list-style-type: none"> No or bad connection between receiver and handset No power at Receiver (batteries low) Mains adapter faulty, set not communicating with Receiver)

C FAULTS AND ERROR CODES IN THE REMOTE

This appendix can be consulted when error messages occur in the application for smartphone and tablet.

C.1 F41 error

This message will appear if there is no or bad Wi-Fi reception, this can be between app and router or Wi-Fi box and router

By closing the App and opening it again, this is solved in most cases.

Cause

The cause may be that the ProControl module is blocked or is too far away from the router. See: **router information**.

Possible solution

- Only place an external router for the ProControl module
- Strengthen existing Wi-Fi signal
- Resetting the router.

C.2 Router information

C.2.1 Minimum requirement

- Compatible with IEEE 802.11n / g / b
- WPA2 encryption
- Radio frequency 2.4 GHz band
- Wireless automatic channel: Automated search for WLAN radio channel that is free from interference.
- Support for the User Datagram Protocol (UDP)

C.2.2 Wi-Fi Router

It is important to think carefully about the location of a router. This device spreads the wifi signal in and around your home. Therefore, preferably choose a central position. You prevent long distances from occurring. Many people put the router in the meter cupboard, because that is where the internet comes in at many households. A bad choice! For a powerful WiFi signal, the router needs as much space as possible. Therefore, do not place the device near a wall or on the ground. Some routers have multiple antennas that you can target. Try to spread these antennas so that you increase the range.

C.2.3 Jammers

Many devices also emit radio waves just like your router. These include microwave ovens, wireless doorbells, baby monitors, Bluetooth adapters, wireless music systems, DECT telephones and security cameras. These devices can disrupt your wireless network (interference), so the Wi-Fi connection is not optimal. Try to keep jammers as far away as possible from the router. Neighboring wireless networks also play a role in the Wi-Fi area.

C.2.4 Frequency

By default, most routers use the 2.4 GHz band to broadcast the Wi-Fi signal. The disadvantage is that this frequency band is very busy, so that there is quickly interference. There are a lot of competing users and jammers using the same radio waves. Since most “older” laptops, smartphones, tablets and other devices can not connect via the 5GHz band, the ProControl module is not suitable for 5GHz band.

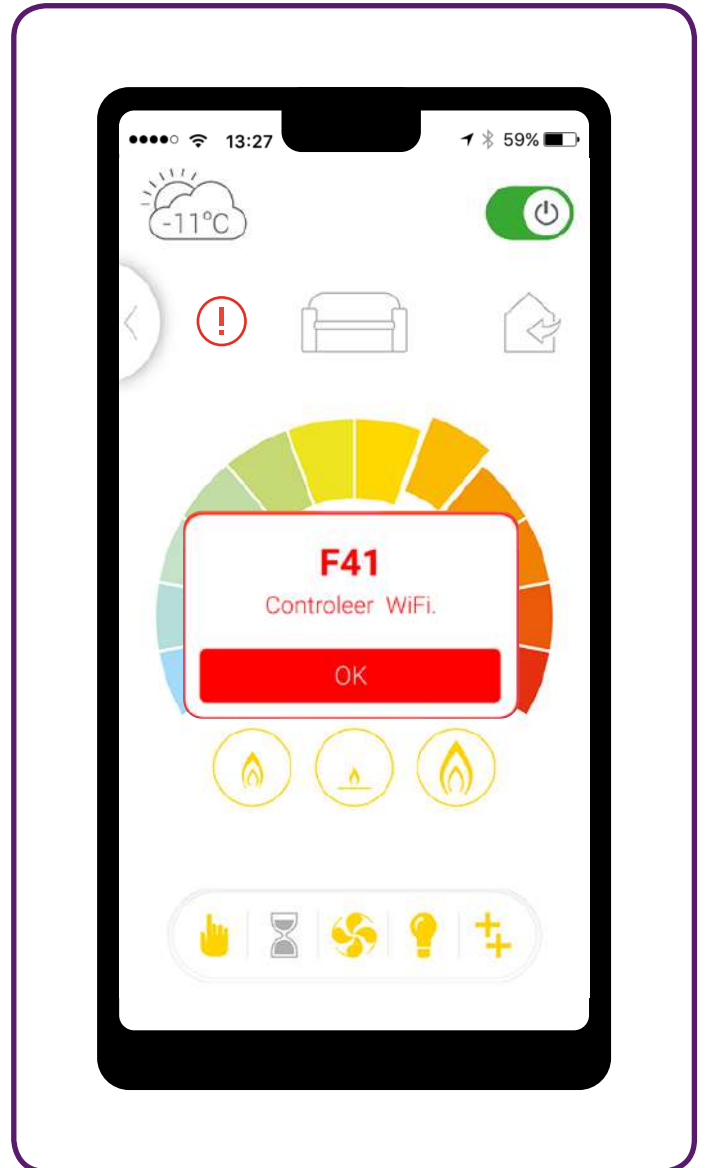

Figure C.1 - Error F41 screen of the ProControl App

D LOCATION TERMINAL

D.1 Terminal location with vertical exhaust (C11)

Distance	Exhaust 1,2 of 3	
At the same roof level	> 6m	*
At a different roof level	> 3m	* & **
On a lower wall	> 2m	*
On a higher sloping surface	> 6m	***

“Distance” = minimum distance required to position the exhaust in order to prevent adverse effects in relation to;

1. A ventilation opening of a used room, toilet or bathroom
2. Supply of heated air when the supply flows through a used room.
3. A window that can be opened and located in the vicinity of a used room, toilet or bathroom.

* If the required distance is not feasible, the rules regarding the exit position have priority.

** If the exhaust is placed at least one meter higher than the inlet opening, or a window that can be opened.

*** If the required distance is not feasible, the exhaust must be placed at least one meter above the highest façade / roof.

(4) The terminal may not be placed closer than 300 mm to an opening in the building such as a window frame.

D.2 Terminal location with Horizontal exhaust (C31)

	Position terminal	dist. (mm)
A*	Directly below an opening, ventilation stone, casement window etc.	600
B	Above an opening, ventilation stone, casement window etc.	300
C	In addition to an opening, ventilation stone, casement window etc.	400
D	Under gutters or drain pipes	300
E	Under eaves	300
F	Under balconies or roofs of open garages	600
G	From a vertical drain pipe	300
H	From an inside or outside corner	600
I	Above ground roof or balcony level	300
J	From a surface opposite the tip	600
K	From an end opposite the tip	600
L	From an opening in the open garage (eg door, window in the house)	1200
M	Vertically from one end to the same wall	1500
N	Horizontally from one end to the same wall	300
P	From a vertical structure on the roof	600
Q	Above the intersection with the roof	150

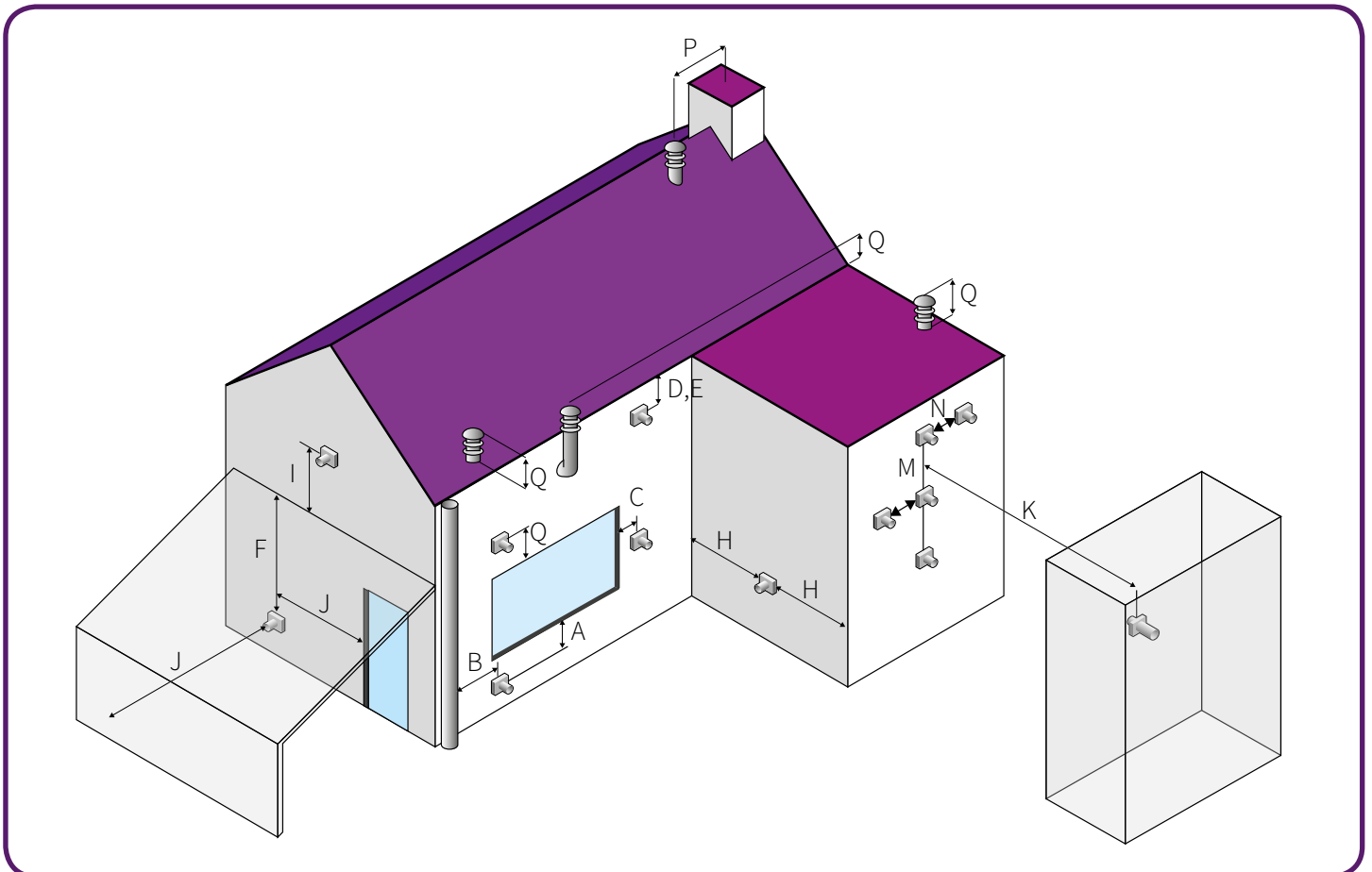

Figure D.1 - Terminal Location

E GENERAL RULES FOR FLUE GAS EXTRACTION

E.1 Power-Fan

For flue configurations that do not function on natural draft, the PowerFan can be used. For extensive installation instructions and the operation of the PowerFan we refer to the manual of the PowerFan.

E.2 Determining the flue gas extraction diameter

The general rule is that you must always adhere to a flue diameter of 200/130. You always start with a vertical length of ½ meter

Except :

- When the stove flue pipe connection is 150/100 mm.
- when your flue only gradates vertically, in which case you may taper directly onto the stove, to a diameter of 150/100.

E.2.1 Determining maximum vertical length:

If you have tapered your flue gas extraction as per the above, to a diameter of 150/100, then the total maximum permitted vertical length of your flue gas extraction is 11 meters. If you are using a diameter of 200/130 then your maximum total length is 22 meters.

E.2.2 Determining maximum horizontal length:

In order to ascertain whether your intended extraction shall function properly, a stove category is determined. After you have determined in which category your fire falls, you search for the corresponding calculation tables.

Each category refers to a table. Each appendix has two tables:

1. A table for horizontal outlet.
2. A table for vertical outlet

You must use the table applicable to you. You calculate your total vertical section (TVS) as well as your total horizontal section (THS). In the table you will find advice; TVS on the vertical axis and THS on the horizontal axis.

An R means you have to put in a restrictor plate in your fireplace. **Figure E.1** shows you where the restrictor plate is inserted. The fireplace comes with three different restrictor plates, each a different size. Use the restrictor plate that gives you the best flames for your fire.

Calculating the Total Vertical Section (TVS)

You calculate the Total Vertical Section by adding up all vertical upward sections in the extraction gradation.

Calculating the Total Horizontal Section (THS)

You calculate the Total Horizontal Section by adding up all horizontal parts in the extraction gradation.

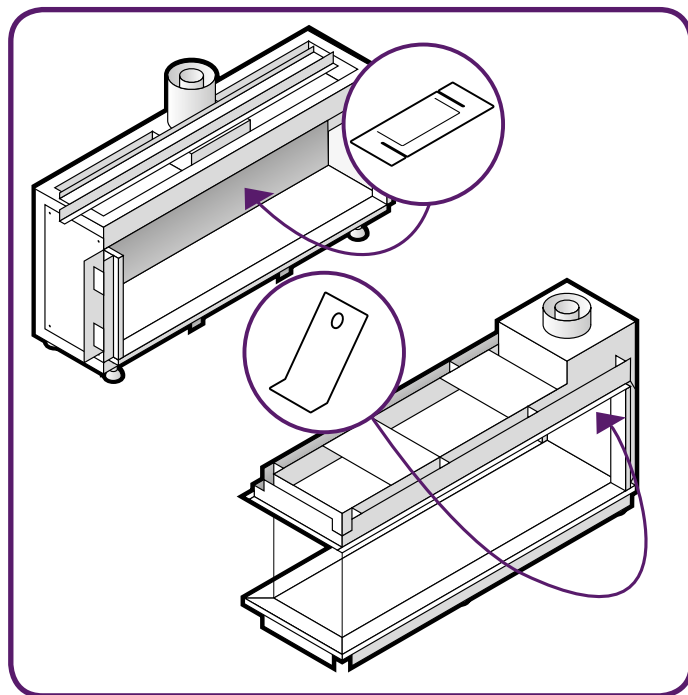

Figure E.1 - Position of the restrictor

E.2.3 Bends

Be aware of the bends in your flue. They provide extra resistance in the system and must therefore be included in the TVS and THS.

There are 2 bend types:

- 45° and 90° bends from vertical to horizontal and vice versa. (Type N)
- 45° and 90° bends from horizontal to horizontal (Type Q)

The first 3 type N bends (from vertical to horizontal) do not need to be included in your calculations. The next type N bends are each calculated as 1 horizontal meter in the THS.

For a type Q bend (horizontal to horizontal) the following applies:

- 90° bend in the horizontal section counts as 2 horizontal meters in the THS.
- 45° bend in the horizontal section counts as 1 horizontal meter in the THS

Extraction sections in a 45° upward pipe:

- 45° upward sections are calculated both vertically and horizontally.

APPENDICES

F CALCULATION TABLE FLUE GAS REDUCTION

The calculation table shows when you need to place a flue gas restrictor

Result Action

- √ No restrictor required
- R Position the restrictor
- X No good operation guaranteed *

F.1 Horizontal terminal flue diameter 200/130

Total vertical Section	11	R	R	R	R	R	R
	10	R	R	R	R	R	R
	9	R	R	R	R	R	√
	8	R	R	R	R	R	√
	7	R	R	R	R	R	√
	6	R	R	R	R	R	√
	5	R	R	R	√	√	√
	4	R	R	√	√	√	√
	3	√	√	√	√	√	√
	2	√	√	√	√	√	X
	1	√	√	√	X	X	X
	0,5	X	√	X	X	X	X
	0	1	2	3	4	5	
Total Horizontal Section							

F.2 Vertical terminal flue diameter 200/130

For a vertical terminal the minimal starting length is 0,5 meter and the minimal vertical section is 1 meter.

Total vertical Section	22	√	X	X	X	X	X	X
	21	R	√	X	X	X	X	X
	20	R	R	√	X	X	X	X
	19	R	R	R	√	X	X	X
	18	R	R	R	R	√	X	X
	17	R	R	R	R	R	√	X
	16	R	R	R	R	R	R	√
	15	R	R	R	R	R	R	√
	14	R	R	R	R	R	R	√
	13	R	R	R	R	R	R	√
	12	R	R	R	R	R	R	√
	11	R	R	R	R	R	R	√
	10	R	R	R	R	R	R	√
	9	R	R	R	R	R	R	√
	8	R	R	R	R	R	R	√
	7	R	R	R	R	R	R	√
	6	R	R	R	R	R	√	X
	5	R	R	R	R	R	√	X
	4	R	R	R	R	√	√	X
	3	√	√	√	√	√	√	X
	2	√	√	√	√	√	X	X
	1	√	√	√	X	X	X	X
	0	1	2	3	4	5	6	
Total Horizontal Section								

* Perhaps the powerfan is a good solution here.

G TECHNICAL DATA

The dataplate specifies for which type of gas, gas pressure and for which country this appliance is intended. The nameplate is attached to a chain. It must remain attached to the chain.

Note: Check whether the appliance is suitable for the gas type and gas pressure on site.

		Gas type ▶		NATURAL GAS					LPG							
		Country of use ▶		I _{2H}	I _{2E}	I _{2E+}	I _{2ELL}	I _{2L} / I _{2EK}	I _{3B/P}	I _{3B/P}	I ₃₊	I ₃₊				
Gas Category ▶		Unit		G20	G20	G20/G25	G20/G25	G25/G25,3	G30/G31							
Supply pressure	mbar	AT,BG,CH DK,ES,FI GB,GR,HR IE,IT,LT LV,NO,PT RO,SE,SI SK,TR	DE,LU PL	20	20	20 / 25	20	25	BG,DK,EE FI,GB,GR HU,HR,IT LY,MT,NL NO,RO,SE SI,SK,TR	AT,CH CZ,DE	AT,BE,CH CZ,DE,ES FR,GB,IE IT,NL,PT SK,TR	CZ,LT NL,SK	30	50	28 - 30/37	30
Burner pressure	mbar			15,4	15,4	16 / 20	15,4	20,0							22,5	
Gross input	kW			21,5	21,5	21,5 / 19	21,5	19,0							19,8	
Net input	kW			19	19	19 / 17,2	19	17,2							16,5	
max. Heat output	kW			16,1	16,1	16,1 / 14,2	16,1	14,2							5,5	
min. Heat output	kW			5,4	5,4	5,4 / 4,7	5,4	4,7							2,2	
(Max.) Gas usage	m ³ /uur			1,6	1,6	1,6 / 2,1	2,1	2,1					0,85	0,85	0,73	0,85
NOx	mg/kWh _{input}					<100									<100	
Pilot						G30-ZP2-312									G30-ZP2-272	
Burnerinjection						1400									560	

Type of flue

C11 / C31 / C91

Type of heat release / control room temperature (Select one)

With electronic control of the room temperature plus week switch

Additional electricity use

At rated heat output

el_{max} 9⁻⁵ kW

With minimal heat emission

el_{min} 9⁻⁵ kW

In standby mode

el_{sb} 9⁻⁵ kW

Other control options

Control of the room temperature with presence detection

Control the room temperature with open window detection

Power requirement for the permanent pilot light

Power requirement for the permanent pilot light (requirements applicable)

P_{pilot} Does not apply

With the option of remote control

With adaptive control of the start

With limitation of the operating time

Efficiency (NCV)

Efficiency at rated heat output

η_{th,nom} 83 %

Efficiency at min. heat output (indicative)

η_{th,min} 54 %

H ECODESIGN

Since 1 January 2018 every fireplace has been provided with an eco-label which is always supplied with the fireplace. The ecolabel shows which category the fireplace belongs to.

H.1 Ecolabels

The ecolabels for the different types of gas are indicated below, respectively G20, G25 and G30.

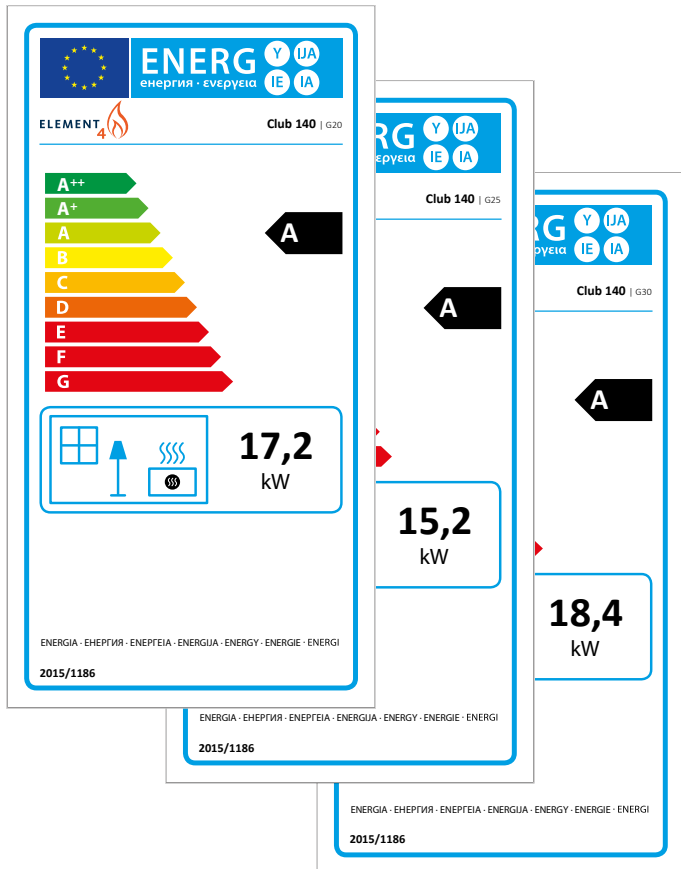

I DIMENSIONAL DRAWINGS

On this page and the following ones you will find dimensional drawings of the 140 models and accessories with some of the important dimensions that you have to take into account when installing and installing your fireplace.

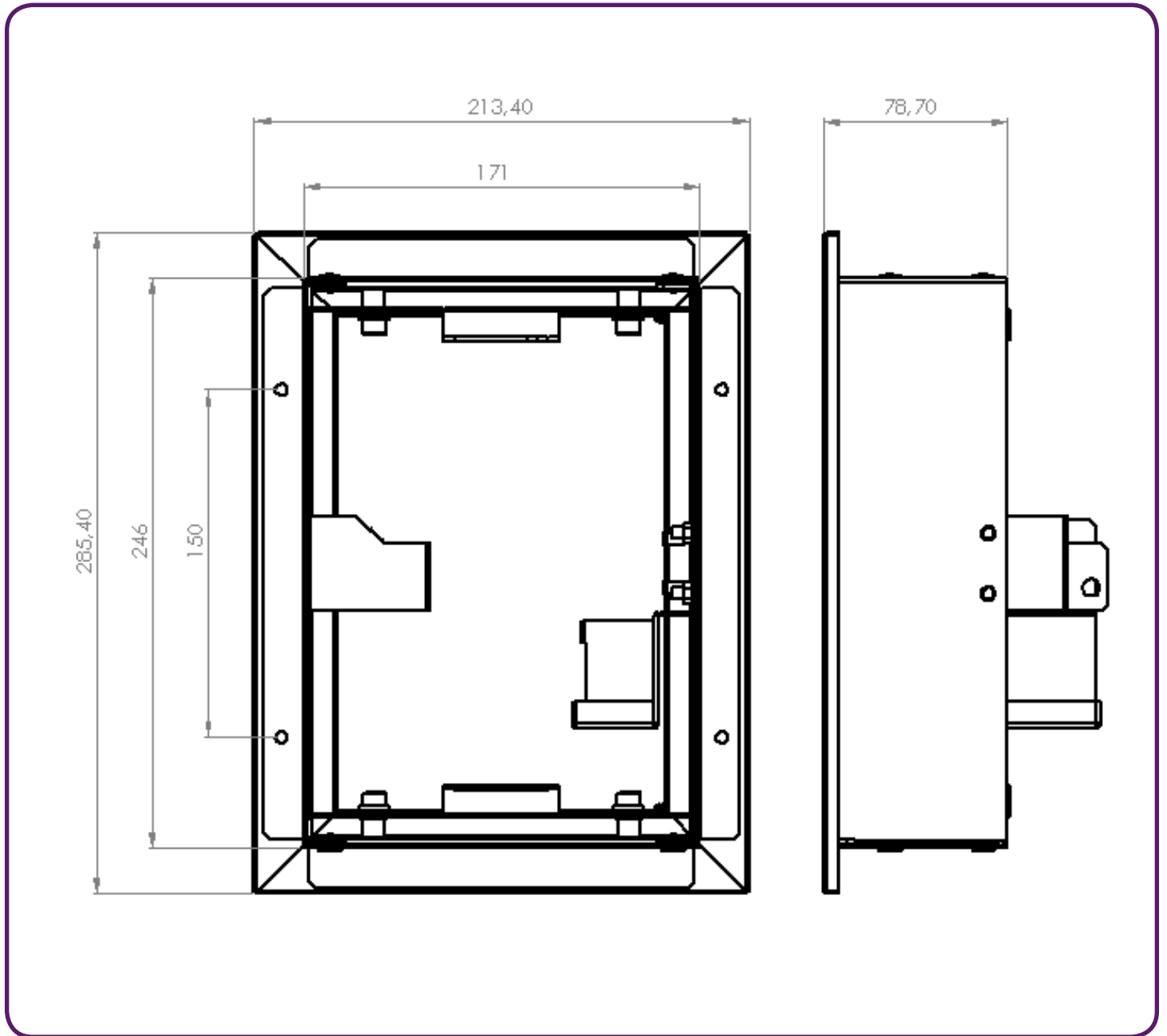
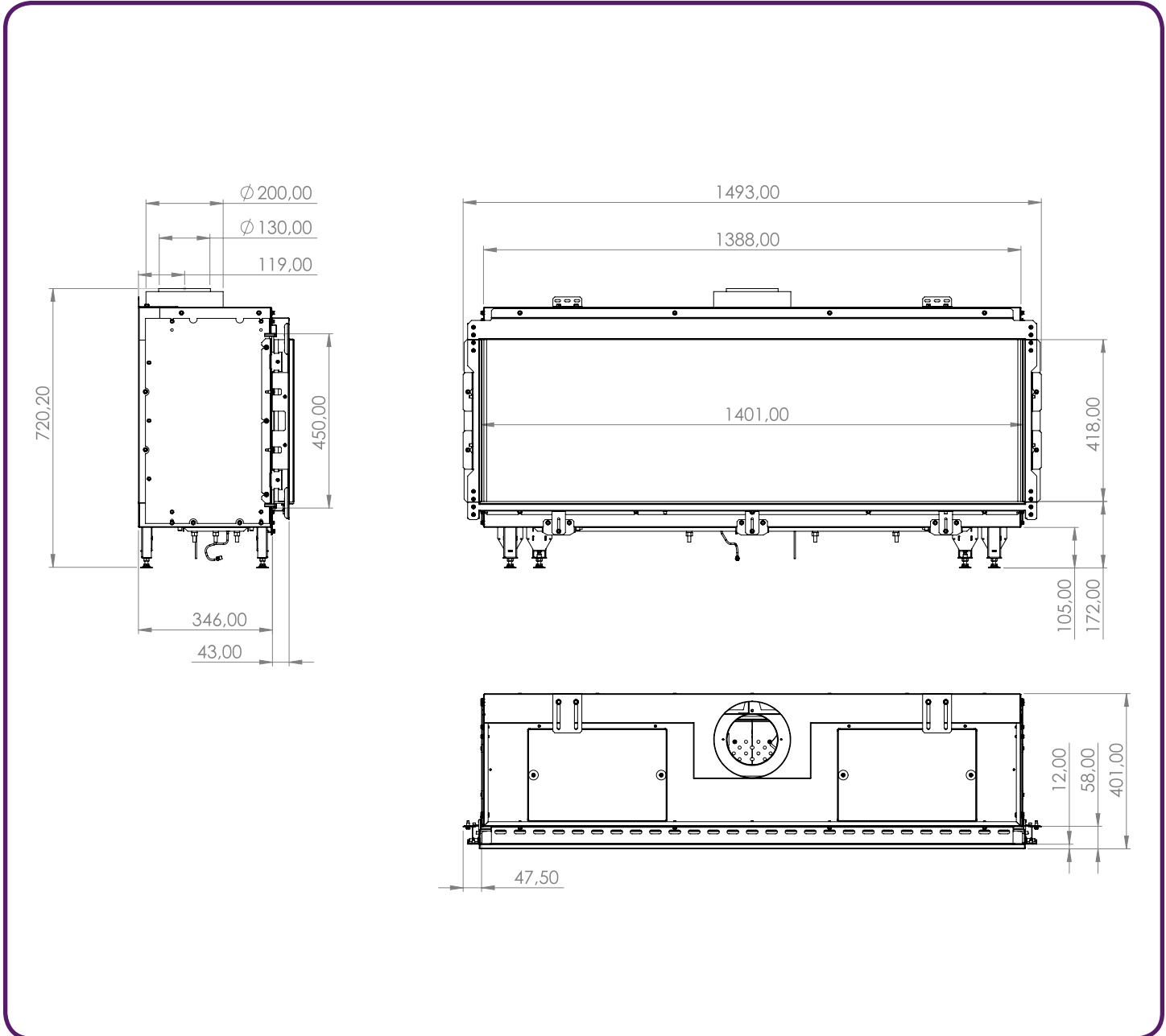

Figure I.1 - Technical drawing of service hatch (BDLE4)



I.2 - Technical drawing of Club 140 F

APPENDICES

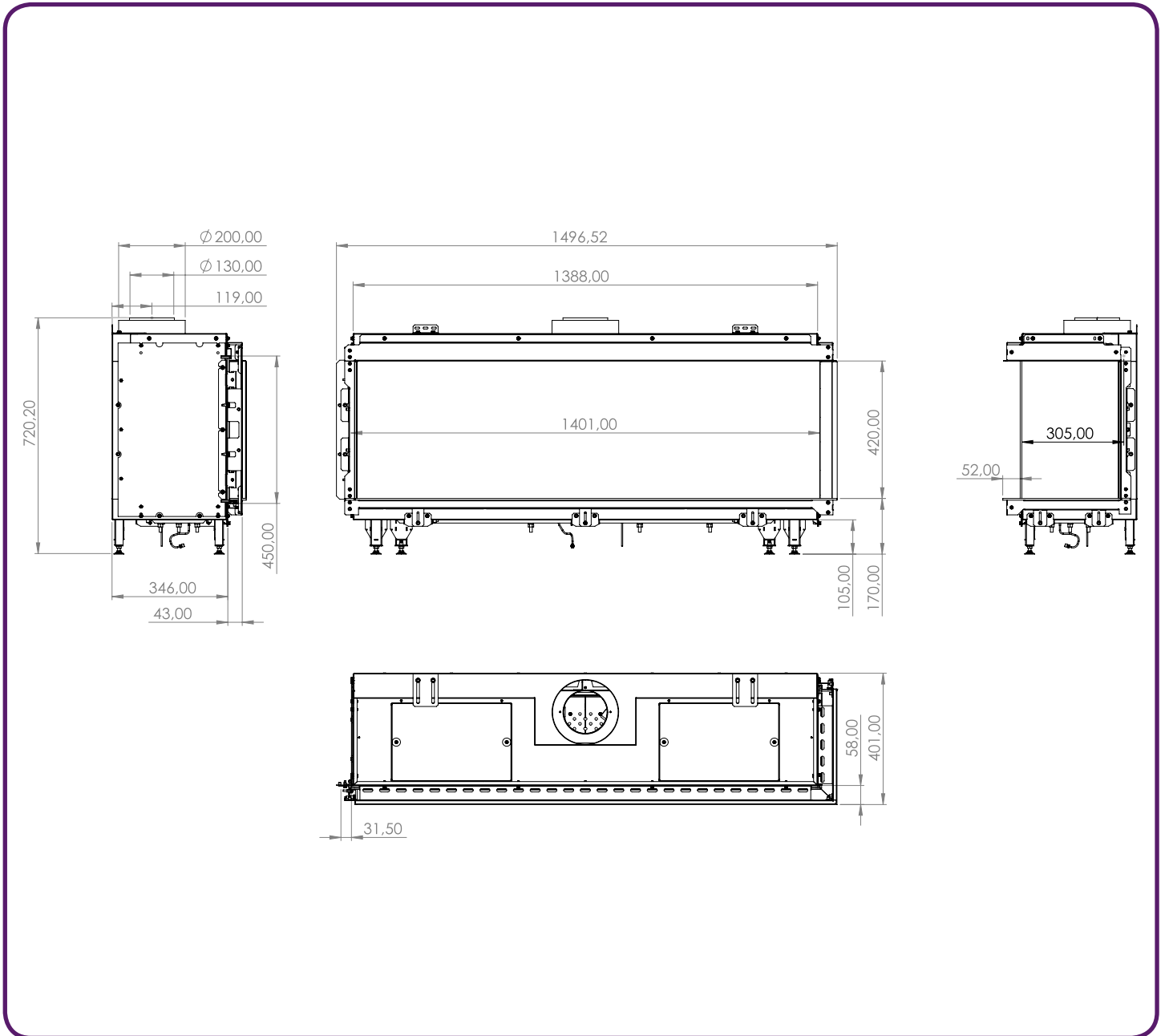
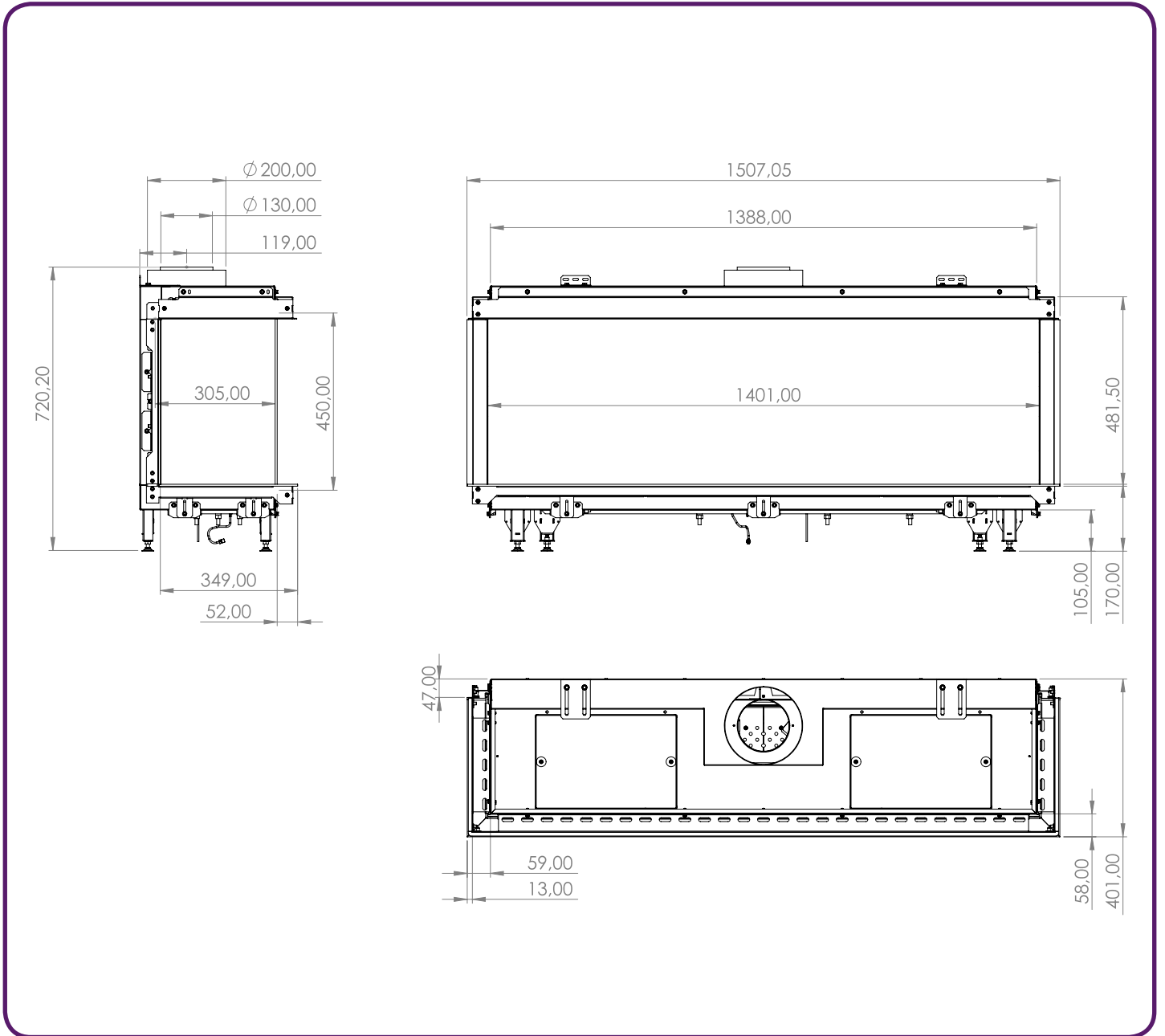

Figure I.3 - Technical drawing of Club 140 C

APPENDICES



I.4 - Technical drawing of the Club 140 3S

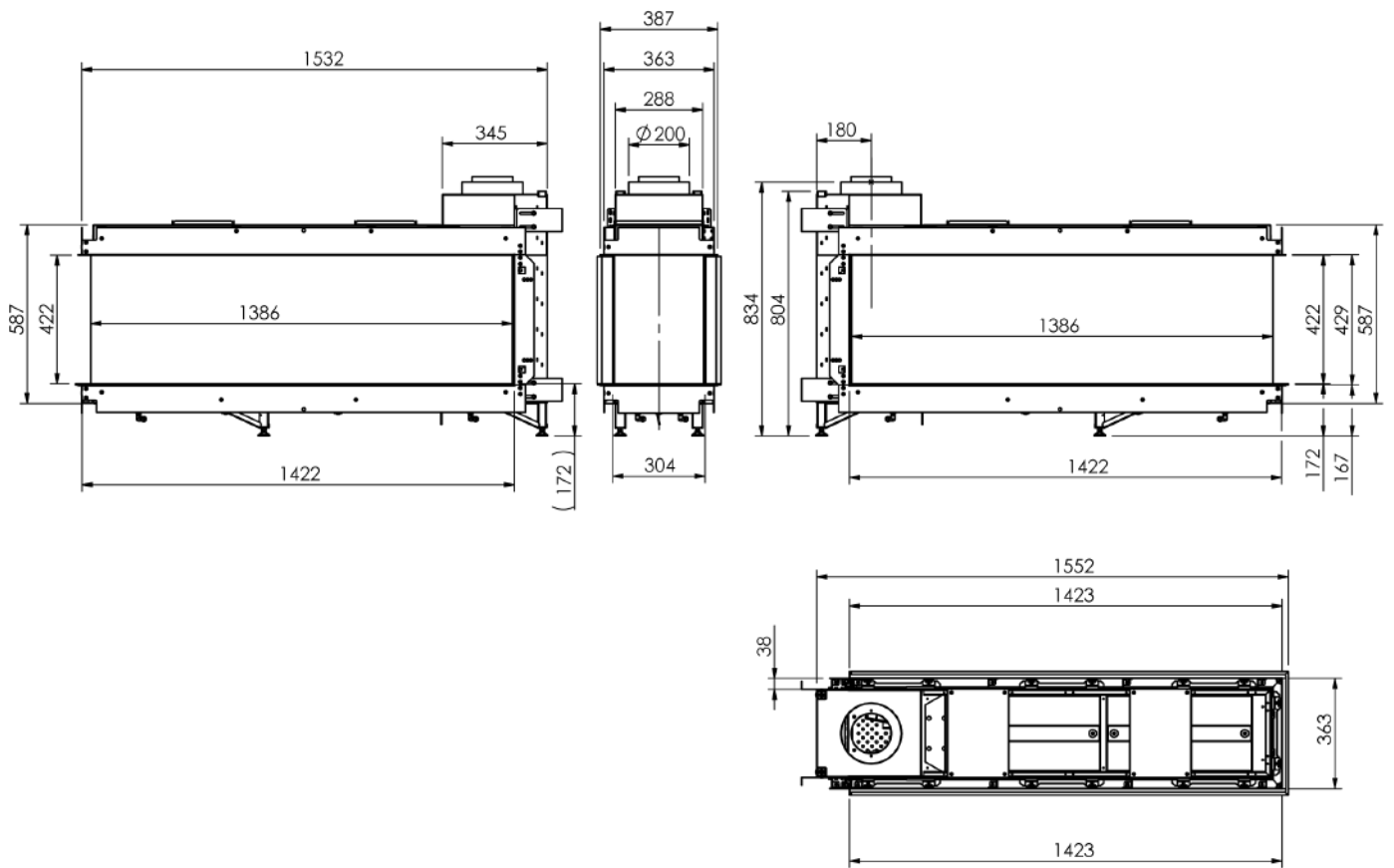
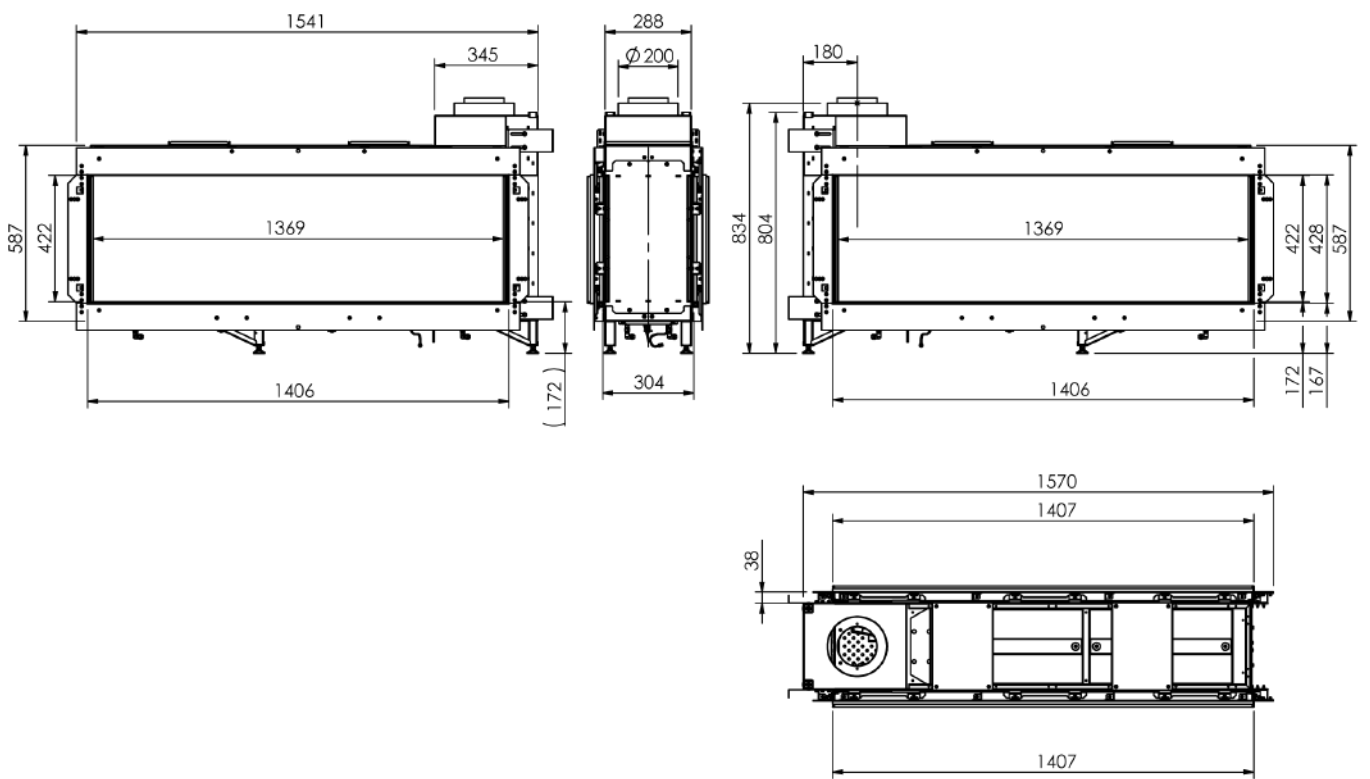

Figure I.5 - Technical drawing of Club 140 RD



1.6 - Technical drawing of the Club 140 T



ELEMENT 4 B.V.

Paxtonstraat 23
8013 RP Zwolle
The Netherlands
Info@element4.nl
www.element4fires.com

RELEASE DATE | 12/06/19